

Chapter 1

Module



A1.1 Power supply, Circuit Breaker
Ethernet switch

A1.2 I/O Module (Metal)

A1.3 IO-Link Module

A1.4 I/O Module (Plastic)

A1.5 SV-Link Module

A1.6 IP20 IO Module

A1.7 Logic distributors

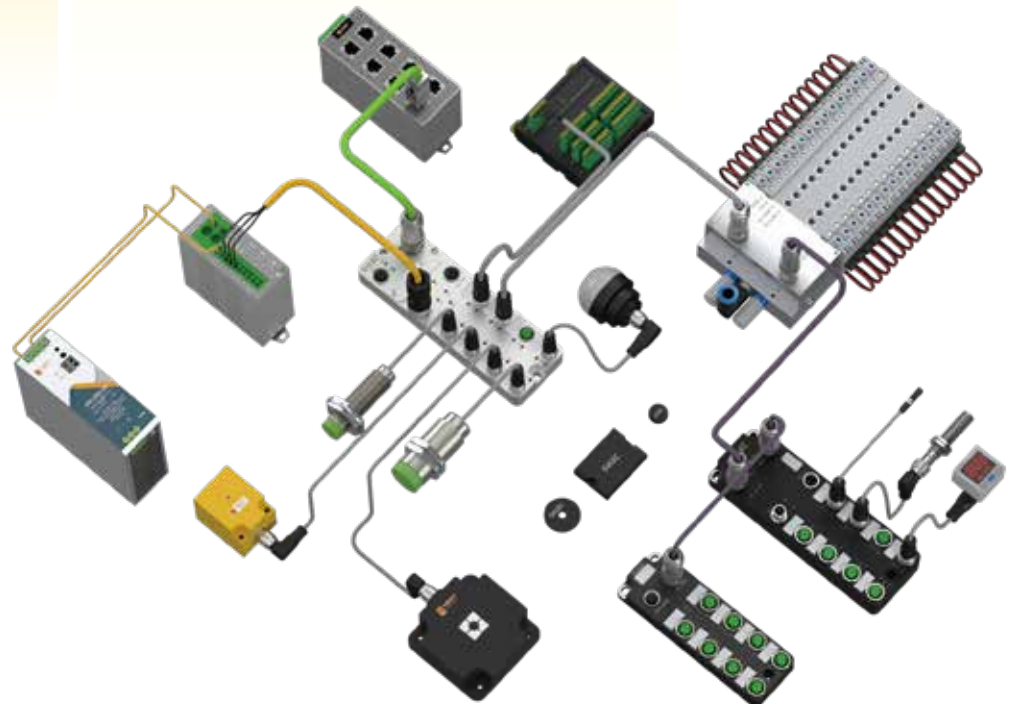
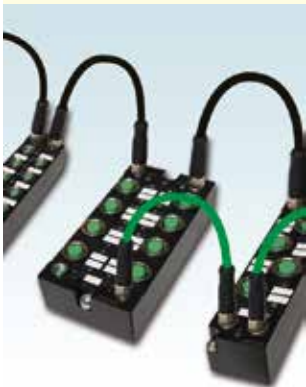

The products above all produced by SVLEC, and have independent intellectual property rights.

Din-rail power module



SVLEC provides customers with cost-effective, standard rail mounting, energy-efficient green power supplies, small volume, lightweight, international EMC (IEC/EN/UL62368, UL61010, UL508 compact, and standard rail mount (35mm) saves a lot of space.

The products are safe and reliable, comply according to standards). Unmanaged switch provides automatic detection of 100 or 1000 Mbps data transmission speed, network segment connection with different transmission speeds, self-crossover, can be equipped with POE function, IP67 /IP20 protection Din-rail powerlevel.



More information please visit
www.svlec.com

POWER SUPPLY MODULE

Power supply

Product dimensional drawing

PR-120-24 Drawing

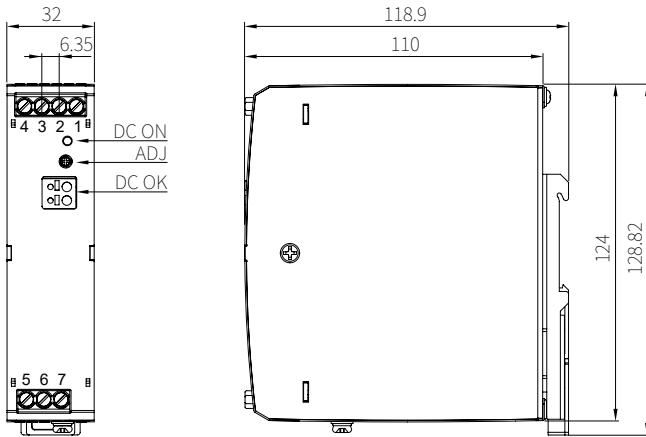

Pin define	
pin	Function
1	-Vo
2	-Vo
3	+Vo
4	+Vo
5	AC(N)
6	AC(L)
7	⊥

PR-240-24 Drawing

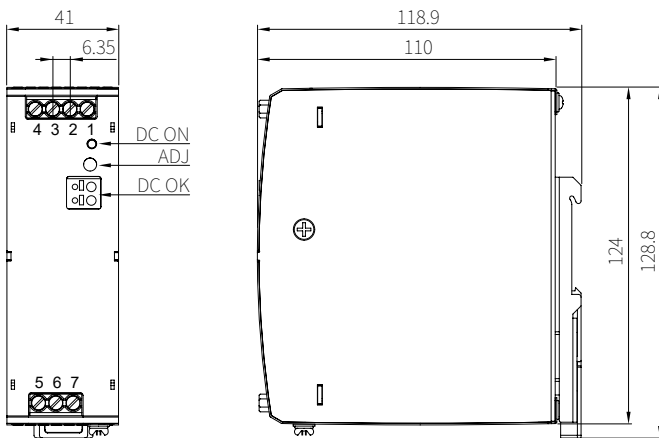

Dimensional unit: mm

DC ON: Output status indicator

ADJ: Output adjustable resistance

Wiring range: 26-10AWG

Tightening torque: Max. 0.4N-m

Rail type: TS35, The rail needs to be grounded

PR-480-24/48 Drawing

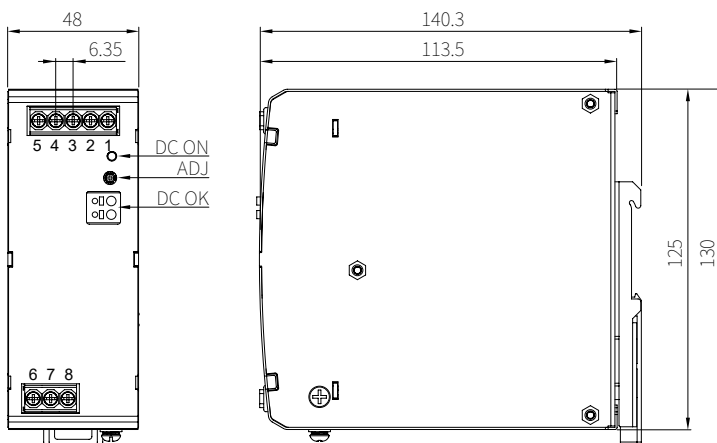

Pin mode	
pin	Function
1	-Vo
2	-Vo
3	-Vo
4	+Vo
5	+Vo
6	AC(N)
7	AC(L)
8	⊥

Dimensional unit: mm

DC ON: Output status indicator

ADJ: Output adjustable resistance

Wiring range: 28-10AWG

Tightening torque: Max. 0.4N-m

Rail type: TS35, The rail needs to be grounded

POWER SUPPLY MODULE

- Input voltage: 85-264VAC/120-373VDC
- AC and DC(same terminal input voltage)
- High efficiency and high reliability
- DCOK function
- Active PFC
- Power On LED Indicator
- Shortcircuit, over current, over voltage, over temperature protection
- Conformance with IEC/EN/UL62368, UL61010, UL508 and other certifications



Ordering information

Type	PR-120-24	PR-240-24	PR-480-48	PR-480-24
Part No.	752405	752410	754810	752420
Technical data				
Output(W)	120	240	480	
Rated output voltage and current (Vo/Io)	24V / 5A	24V / 10A	48V / 10A	24V / 20A
Output voltage adjustable range ADJ(V)	23.5-28.0	24.0-28.0	48.0-55.0	24.0-28.0
Efficiency 230VAC(%)Typ.	94			
Input voltage range	85-264 VAC			
Input voltage frequency	47-63 Hz			
Input current	0.75A/230 V AC--1.5A/115 V AC	1.5A/230 V AC--3A/115 V AC	2.5A/230 V AC--5A/115 V AC	
Output voltage accuracy:	±1.0			
Linear regulation rate:	±0.5			
Load regulation rate: 0%-100%	±1.0			
DC OK Function	30V DC/1A Max.			
Short circuit protection: The recovery time less than 10s after the shortcircuit status finished	Long-term short-circuit protection, self-recovery, the recovery time is less than 10s			
Working temperature	-40 ... 70° C			
Working humidity	20 ...95 %RH			
Safety standard	According to IEC/EN/UL62368/UL61010/UL508			
Safety certification	EN62368/UL61010			
Security Level	CLASSI			
MTBF: MIL-HDBK-217F@25° C	> 300,000h			
Housing material	Metal (AL1100, SPCC) Plastic (PC940)			
Cooling method	Natural air cooling			
Electromagnetic interference	Conducted Emission	CISPR32/EN55032 CLASS B		
	Radiation disturbance	CISPR32/EN55032 CLASS B		
	Harmonic current	IEC/EN61000-3-2 CLASS A		
Electromagnetic sensitivity	electrostatic discharge	IEC/EN61000-4-2 Contact ±6KV/Air ±8KV		
	Radiated susceptibility	IEC/EN61000-4-3 10V/m		
	Pulse group immunity	IEC/EN61000-4-4 ±4KV		
	Surge immunity	IEC/EN61000-4-5 Line to line ±2KV/line to ground ±4KV		
	Conducted disturbance immunity	IEC/EN61000-4-6 10Vr.m.s		
	Voltage dips, drops and short interruption immunity	IEC/EN61000-4-11 0%, 70%		

Electronic circuit breakers



24 V DC electronic circuit control

Electronic circuit breakers feature high turn-on capacitance.

Compact electronic circuit breakers combine safety and cost-effectiveness.

- Reliable overload protection and short-circuit protection.
- Electronic circuit breakers are capable of starting loads of 50,000 microfarads or even higher , not need to set a higher current rating.
- Four- and eight-channel products with current ratings from 1 to 10 A .
- The high channel density of the electronic circuit breaker saves space in the control cabinet.
- The devices feature an active current limit function to prevent overload in the event of a short circuit in the power supply unit.



More information please visit
www.svlc.com

ELECTRONIC CIRCUIT BREAKERS

The device monitors the current and provides full control over the system status, provides a solution for system components and switch-mode power supplies obstacle protection.

电子断路器

Drawing



Simplifies the wiring of the switchgear

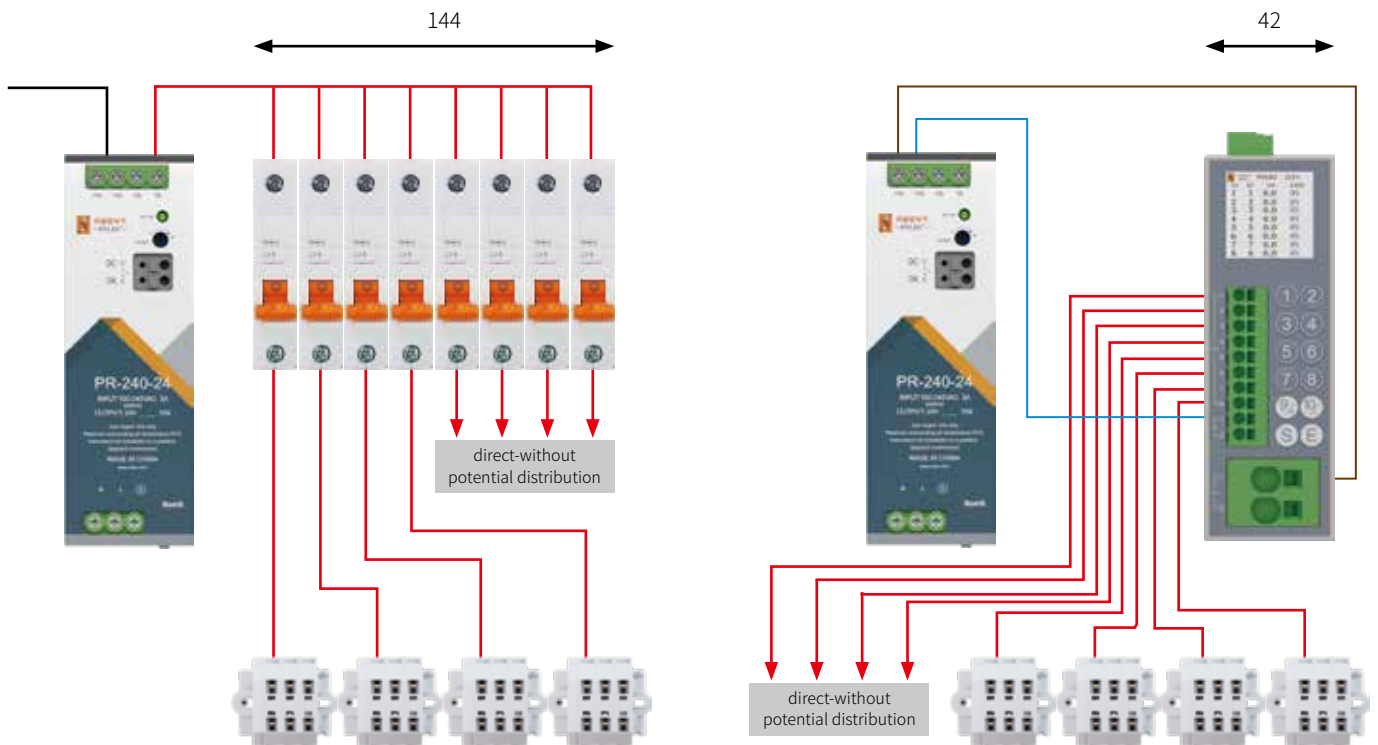

ELECTRONIC CIRCUIT BREAKERS

- Overcurrent protection
- Adjustable current range
- Advance alarms (90%)

- 1、精确、快速而可靠地切断二次侧过载和短路通道——即使在电缆较长和导线截面积较小时
- 2、选择性脱扣，尤其是带有有源电流功能的电子断路器
- 3、通过数字量输入和输出进行远程操作
- 4、读取功能（通信）——通过基于数字量输入和输出的串行数据传输
- 6、每个通道的额定电流均可单独设置
- 7、符合 EN 60204-1 标准，能在五秒内可靠切断接地故障（如图所示）



Ordering information	4 路电子断路器	4 路电子断路器 带 IO-Link 通讯
Type	PRA0401	PRA0402
Part No.	760001	760002
Technical data		
Input voltage	24 V DC (18...30 V DC)	
Output current (Adjustable)	1A、2A、3A、4A、5A、6A、7A、8A、9A、10A, Rotary switch via countersunk	
Output impact capability	Max. 20 mF (per channel)	
Controls the pulse width	IO	IO-Link communication
Control output: overall alarm output	NC, dry nodes output	Diagnosis of communication process data
General data		
Connect	Spring terminal	
Input terminal	2x16 mm ²	
Output terminal	Output channel 1x4 mm ²	
Alarm Terminal	2.5 mm ²	
Installation:	DIN-TH35 (EN 60715)	
Temperature range	-30 ...70° C	
Dimensions (length×width× height)	89.4×47×90 mm	

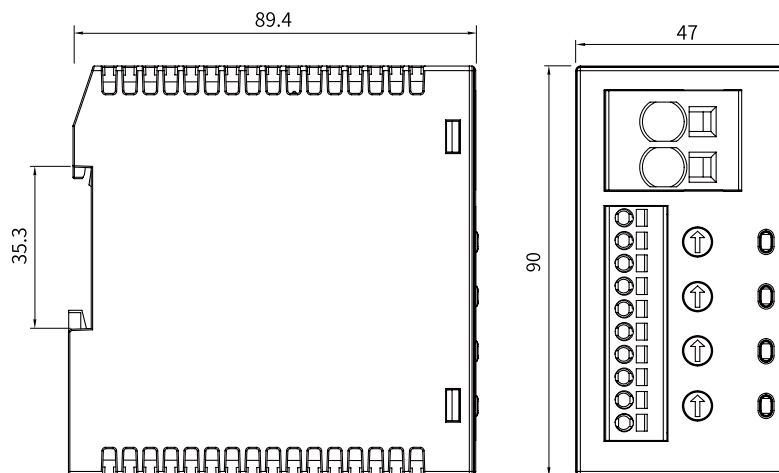

PRB410/PRB411 Dimensions

ELECTRONIC CIRCUIT BREAKERS

- Overcurrent protection
- Adjustable current range
- Advance alarms (90%)
- Visualization with display screen
- Remote visual monitoring and control can be achieved through the IO-LINK/Modbus TCP interface.



Ordering information	Electronic circuit breakers	with IO-Link	Equipped with Modbus TCP communication
4way, Type	PRB0412	PRB0413	PRB0414
4way, Part No.	760021	760022	760023
8way, Type	PRA0801	PRA0802	PRA0805
8way, Part No.	760011	760012	760013
Technical data			
Input voltage	24 V DC (18...30 V DC)		
Output current (Adjustable)	1A、2A、3A、4A、5A、6A、7A、8A、9A、10A, Adjustment via panel buttons		
Output impact capability	Max. 20 mF (per channel)		
Controls the pulse width	IO	IO-Link communication	Modbus TCP communication
Control output: overall alarm output	NC , dry nodes output	Diagnosis of communication process data	
General data			
Connect	Spring terminal		
Input terminal	2x16 mm ²		
Output terminal	Output channel 1x4 mm ²		
Alarm Terminal	2.5 mm ²		
Installation:	DIN-TH35 (EN 60715)		
Temperature range	-30 ...70° C		
Dimensions (length×width× height)	80×42×125 mm		

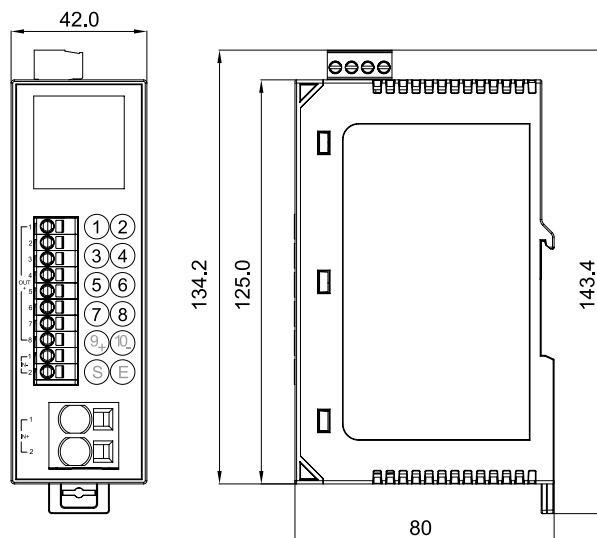

Ethernet switch



Store and forward

Multiple address function

QoS



More information please visit
www.svlec.com

Product dimensional drawing

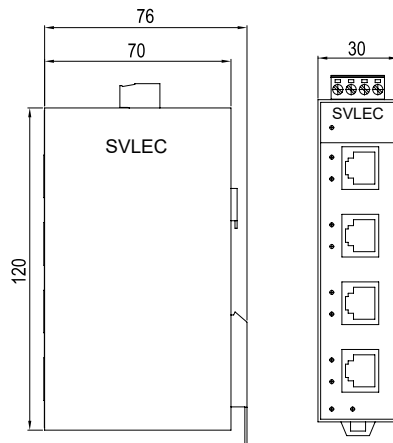

EST250
5 port ethernet switch

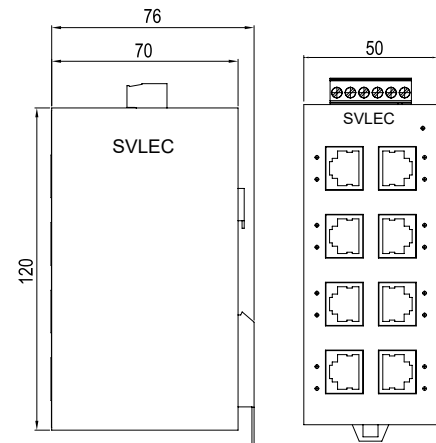

EST280
8 port ethernet switch

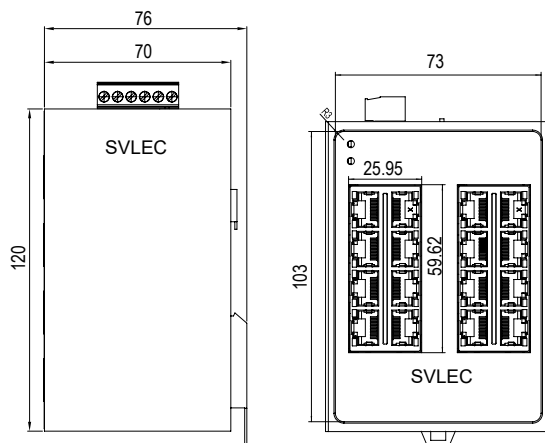

EST290
16 port ethernet switch

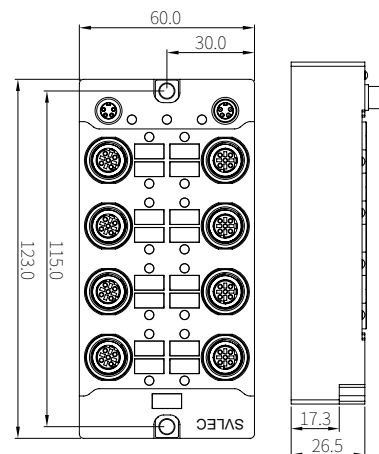

ESP180
8 port ethernet switch IP67

Benefits

1 Store and forward

All packets received by the switch are saved and their validity is verified. Invalid or incorrect packets (> 1522 bytes or CRC errors) and fragmented data (< 64 bytes) will be rejected. The valid packet data is forwarded by the switch. The switch forwards the data using the data transfer rate used in the destination network segment.

3 Quality of service (QoS)

With the help of the quality of service function, the switch can prioritize PROFINET traffic. To this end, the switch detects the QoS priority of Ethernet packets and forwards Ethernet packets with higher priority first.

2 Multiple address function

By evaluating the source address in the data packet, the switch can independently obtain the address of the terminal device connected to the port. Only packets with unknown addresses that carry the port source address or multipoint/ broadcast address in the destination address area are forwarded through the corresponding port. The switch can store up to 4096 addresses in its address table for 40 seconds. This is important when more than one terminal device is connected to one or more ports. Thus, several independent subnets can be connected to a single switch.

SPLIT

- Adaptive and self-cross detection simplifies installation and setup
- Local diagnostic indicator with LED
- The RJ45 port has a transfer rate of 100 Mbps



Ordering information	6 Port ethernet split
Type	ECT260
Part No.	6825260
Technical data	
Protocol	EtherCAT
Synchronization method	DC/SM
Duplex mode	Full-duplex
Maximum communication speed	100 Mbit/s (100Base-Tx)
Topological structure	Star configuration
Cascading branching devices	Support
Network cable recognition	Auto MDI/MDIX
Power voltage	24VDC(20.4VDC~28.8VDC)(-15%~+20%)
Internal consumption current	约 160mA
EtherCAT Channel	1 input, 5 output
Maximum transmit speed	100Mbps
Network port/Ethernet cable	Standard RJ45 port, Eth cable under 100M
Working temperature	-10 ... +55° C
Storage temperature	-25...+70° C
Humidity	10% RH~ 95%RH
Dimensions (L×W×H)	47×89.4×90 mm

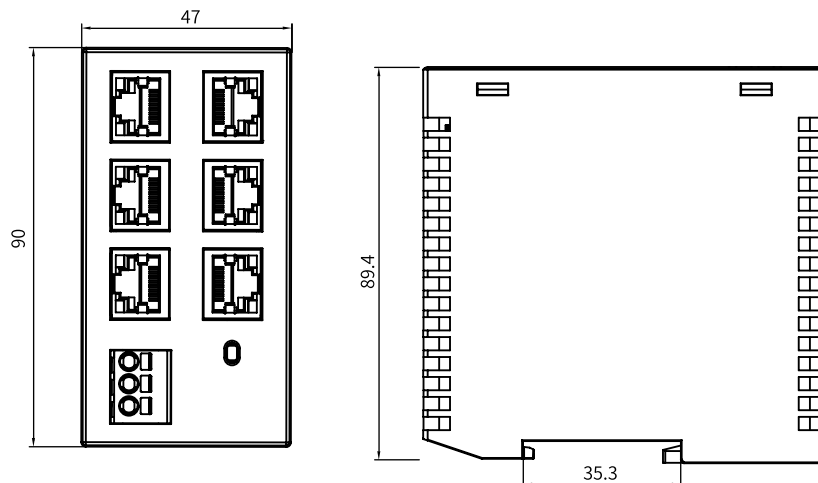

UNMANAGED ETHERNET SWITCHES

Ethernet 5-port switch IP20

- Adaptive and self-cross detection simplifies installation and setup
- Local diagnostic indicator with LED
- RJ45 port has a transfer rate of 10/100 Mbps



Ordering information	Fast Ethernet Switch	POE Switch
Type	EST250	EST251
Part No.	6825250	6825251
Technical data		
POE Function	/	Support
POE Protocol	/	IEEE 802.3at (70W)
POE Port	/	4
Transmission	EtherNet	
Type	5 port Fast Ethernet switch	
Port	5 x RJ45 Spring force clamp	
Connection method	Adaptivity and and Self crossover	
Transmit methods	RJ45 RJ45 network cable twisted pair	
Transmit speed	10 / 100 Mbps	
Basical function	Unmanaged switch/adaptive, compliant (IEEE802.3, store and forward switching mode)	
Other function	Autonegotiation	
Status indicator	LED: U ₅ , Each port is connected	
Power voltage	24 V DC	
Power voltage range	12 V DC ... 30 V DC	48 V DC
Residual wave	3.6 V _{PP}	36 V DC ... 57 V DC
Current consumption	140 mA (U ₅ =24 V DC)	
Installation type	DIN rail	
AX	Terminal design	
Protection level	IP20	
Housing	Aluminum	
Temperature range (working)	-25 ... 60° C	
Temperature range (stocking/ shipping)	-30 ... 70° C	
Fastener	Buckle into the support rail TH35 (EN60715)	
Dimensions (length× width× height)	70×28×110 mm	

UNMANAGED ETHERNET SWITCHES

Ethernet 8-port switch IP20

- Adaptive and self-cross detection simplifies installation and setup
- Local diagnostic indicator with LED
- The RJ45 port has a transfer rate of 10/100 Mbps



Ordering information	Fast Ethernet Switch	Gigabit Ethernet Switch
Type	EST280	EST282
Part No.	6825280	6825282
Technical data		
Transmission	EtherNet	
Type	8 Ports Fast Ethernet switch	8 Ports Gigabit Ethernet switch
Port	8 x RJ45 Spring force clamp	
Connection method	Adaptivity and and Self crossover	
Transmit methods	RJ45 network cable twisted pair	
Transmit speed	10 / 100 Mbps	10 / 100 / 1000 Mbps
Basical function	Unmanaged Switch/Adaptive, follows IEEE802.3, store-and-forward switching mode	
Other function	Autonegotiation	
Status indicator	LED: U _S , Each port is connected	
Power voltage	24 V DC	
Power voltage range	12 V DC... 30 V DC	
Residual wave	3.6 V _{pp}	
Current consumption	140 mA (U _S =24 V DC)	
Installation type	DIN Rail	
AX	Terminal design	
Protection level	IP20	
Housing Material	Aluminum	
Temperature range (working)	-25 ... 60° C	
Temperature range (stocking/ shipping)	-30 ...70° C	
Fastener	Buckle into the support rail TH35 (EN60715)	
Dimensions (length× width× height)	70×50×120 mm	

Ethernet-based network systems are becoming more and more important in industrial automation. SVLEC offers a wide variety of Ethernet-based systems and network components for machines and plant equipment, such as Profine or Ethernet/IP.

Get a complete system from SVLEC is available,link the parts of an Ethernet system using Ethernet is more easily. As a result, 5-port and 8-port Ethernet switches have been added to the Ethernet product line.

Up to 5 ports and 8 Ethernet devices can now be radially connected to a single component. It is supported by RJ45 ports and transfer rates of 10 and 100 MBPS. The transmission speed is automatically set through the adaptive function. Reliably eliminate wiring errors with automatic cross function,because the module does not automatically confirm what type of cable is being used.

UNMANAGED ETHERNET SWITCHES

Ethernet 16-port switch IP20

- Adaptive and self-cross detection simplifies installation and setup
- Local diagnostic indicator with LED
- The RJ45 port has a transfer rate of 10/100 Mbps



Ordering information	Fast Ethernet Switch	Gigabit Ethernet Switch
Type	EST290	EST291
Part No.	6825290	6825291
Technical data		
Transmission	EtherNet	
Type	16 Ports Fast Ethernet switch	16 Ports Gigabit Ethernet switch
Port	16 x RJ45 Spring force clamp	
Connection method	Adaptivity and and Self crossover	
Transmit methods	RJ45 network cable twisted pair	
Transmit speed	10 / 100 Mbps	10 / 100 / 1000 Mbps
Basical function	Unmanaged Switch/Adaptive, follows IEEE802.3, store-and-forward switching mode	
Other function	Autonegotiation	
Status indicator	LED: U ₅ , Each port is connected	
Power voltage	24 V DC	
Power voltage range	12 V DC... 30 V DC	
Residual wave	3.6 V _{pp}	
Current consumption	140 mA (U ₅ =24 V DC)	
Installation type	DIN Rail	
AX	Terminal design	
Protection level	IP20	
Housing Material	Aluminum	
Temperature range (working)	-25 ... 60° C	
Temperature range (stocking/ shipping)	-30 ...70° C	
Fastener	Buckle into the support rail TH35 (EN60715)	
Dimensions (length× width× height)	70×50×120 mm	

Ethernet-based network systems are becoming more and more important in industrial automation. SVLEC offers a wide variety of Ethernet-based systems and network components for machines and plant equipment, such as Profine or Ethernet/IP.

Get a complete system from SVLEC is available,link the parts of an Ethernet system using Ethernet is more easily. As a result, 5-port and 8-port Ethernet switches have been added to the Ethernet product line.

Up to 5 ports and 8 Ethernet devices can now be radially connected to a single component. It is supported by RJ45 ports and transfer rates of 10 and 100 MBPS. The transmission speed is automatically set through the adaptive function. Reliably eliminate wiring errors with automatic cross function,because the module does not automatically confirm what type of cable is being used.

ETHERNET SWITCHS

Ethernet 8-port switch IP67



Power connector
 Pin 1 +24 V DC Us
 Pin 2 +24 V DC Up
 Pin 3 GND
 Pin 4 GND

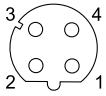

LAN Slot allocation
 Pin 1 transfer +
 Pin 2 reception +
 Pin 3 transfe -
 Pin 4 reception -



Applicable to Ethernet interfaces

914521



Applicable to power ports

908611



908631



Ordering information

Type	ESP180
Part No.	6825680
Technical data	
Transmission 1	Ethernet
Port	8 (M12 Female)
Connection method	D Code
Transmission principle	Twisted pair
Transmit speed	10 / 100 MBit/s
Transmit distance	100 m (Each part)
Signal LED	Data connection/receiving
Basical function	Unmanaged switch/adaptive, IEEE802.3 standards, Store-and-forward switching mode, IEEE802.1Pstandards, PTCP
Other function	Autonegotiation
Status indicator	LED : US, Each port connection
Cascade depth	Network, line, and star structures: any
Max cable length (twisted pair)	100 m
Power voltage	24 V DC (M8 male connector)
Residual wave	3.6 V _{pp}
Power voltage range	12 V DC...30 V DC
Current consumption	40 mA (U _s =24 V DC)
Max current consumption	40 mA (Per port +10 mA)
Current consumption	40 mA...80 mA (24 V DC)
Size (L× W× H)	50×150×24.6 mm
Protection level	IP67
Temperature range (working)	-25..+ 60 ° C
Temperature range (stocking/ shipping)	-40...+70 ° C
Humidity (working)	10.....95%
Humidity (stocking/ shipping)	10.....95% (No condensation)
Air pressure (working)	86 kPa ... 108 kPa (Elevation of 2000 m)
Air pressure (stocking/ shipping)	86 kPa ... 108 kPa (Elevation of 3500 m)
Installation type	Wall installation
AX	Stand-alone
Electromagnetic compatibility	2014/30/EU 2014/30/EU standard
Type of test	EN 60068-2-27 / IEC 60068-2-27 Impact resistance standard
Test Results	Operation: 30 g, 6 ms continuous detection, 5g, 30 ms continuous detection

IP67 GIGABIT INDUSTRIAL SWITCHES

- According to EN50155 , Applicate for railway , shipping
- IEC/EN 61000-4 IP67 protection
- -40°C ~75°C operate temperature
- 12V~60VDC wide range input
- Compact design
- Unmanaged switch , without configuration



For eth: screw terminal



917941

For eth: quick lock



921783

Ordering information	Screw terminal	Quick lock
Type	ESP280	ESP281
Part No.	6825780	6825781
Technical data		
Port for Eth	M12 8pin, X-code, male (917941)	M12 8pin, X-code, male (921783)
Protocol standards	IEEE 802.3, 802.3i, 802.3u, 802.3x, 802.3ab	
Gigabit port configuration	8*M12, 8pin, X-code, female	
Form of power terminal port	1*M12, 4pin, A-code, male	
Status indicator light	8* Link/ACT	
Input indicator light	PWR	
Limit input voltage	12-60VDC	
Input Current	0.80A MAX(@24VDC)	
Rated voltage tolerance	±40%	
Dual redundant power supply input	Support	
Class S2 (10ms) Break	Support	
Reverse connection protection	Support	
Protection	IP67	
Product dimension	185 x 170 x 53.4mm	
Installation	Rail / Flat mount	
Vibrancy	50m/s ²	
Working temperature	- 40...+75 ° C	
Storage temperature	- 40...+85 ° C	
Humidity	5%RH — 95%RH,	
Maximum power of the whole machine	6.59W	

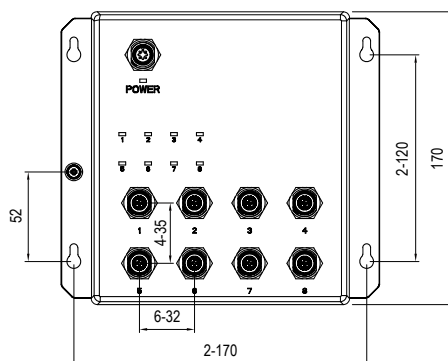

Remote I/O module



IP20 module



IP67 module



Safety module



Gateway



Compact module



Compact module



IO-LINK
slave station



IO-LINK
master station



IP20 Remote I/O module



REMOTE I/O MODULE



For demanding I/O module

The bus module with strong anti-interference ability can adapt to any harsh electrical and Mechanical operating environment, include PROFINET, EtherNet/IP, EtherCAT, PROFIBUS, DeviceNet, CC-Link IE, SV-Link, IO-Link...Our products are compatible.

 <p>Metal module</p>	 <p>Industrial plastic module</p>	 <p>Compact module</p>
 <p>SV-Link module</p>	 <p>IP20 Remote I/O module</p>	 <p>IO-Link module</p>

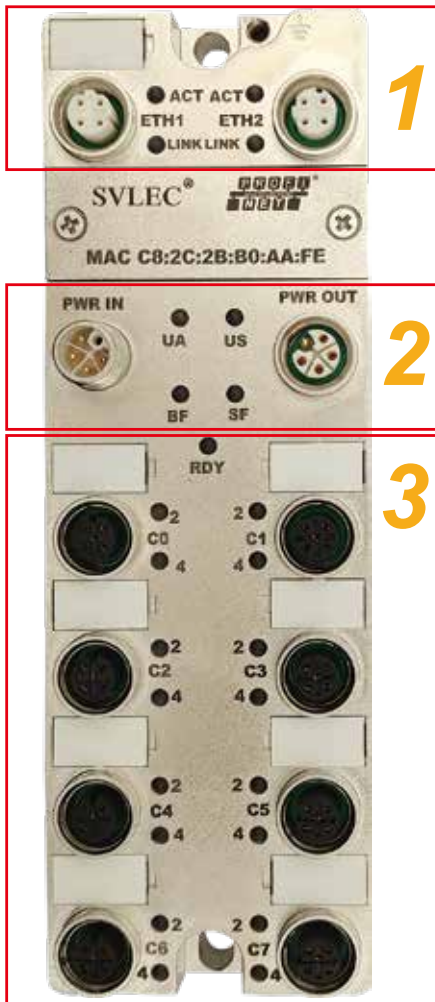

1 Accessories

Applicable to Ethernet interfaces

Part No.: 914521



Ethernet connector M12 D-code



1= TD +
2= RD +
3= TD -
4= RD -

2 Accessories

Applicable to power ports

L-Code Part No.: 912743 (M)
912952 (F)



Power connector M12 L-code



1= 24V (US)
2= GND-UA
3= GND-US
4= 24V (UA)
5= FE (PE)

3 Accessories

Part No.:
912701
912721
912761
912781



Part No.:
941201
941221

Part No.:
941131

DI/DO Connector M12 A-code

Wiring instance

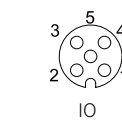

b) Double output signals - that is, 1 connector is connected to 2 digital output signal

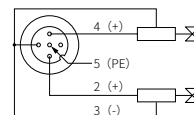

a) Double input signals - that is, 1 connector is connected to 2 digital input signal

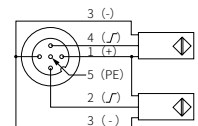

c) Input and output signals - that is, 1 connector with 1 digital input plus 1 digital output signal

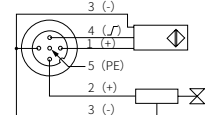

LED instructions

Input signal (two-color LED)
Output signal (two-color LED)
UA/US indicator (two-color LED)
ACT Indicator
LINK Indicator light

Green: The input is active. Red: The input power is short-circuited and overloaded
Green: The output signal is activated. Red: the output signal is overloaded
Green: The working power supply and the load power supply are working properly, Red: the load voltage is lower than 18V DC.
Yellow: Data is being exchanged
Green: The network is connected. Off: The network is not connected

REMOTE I/O MODULE

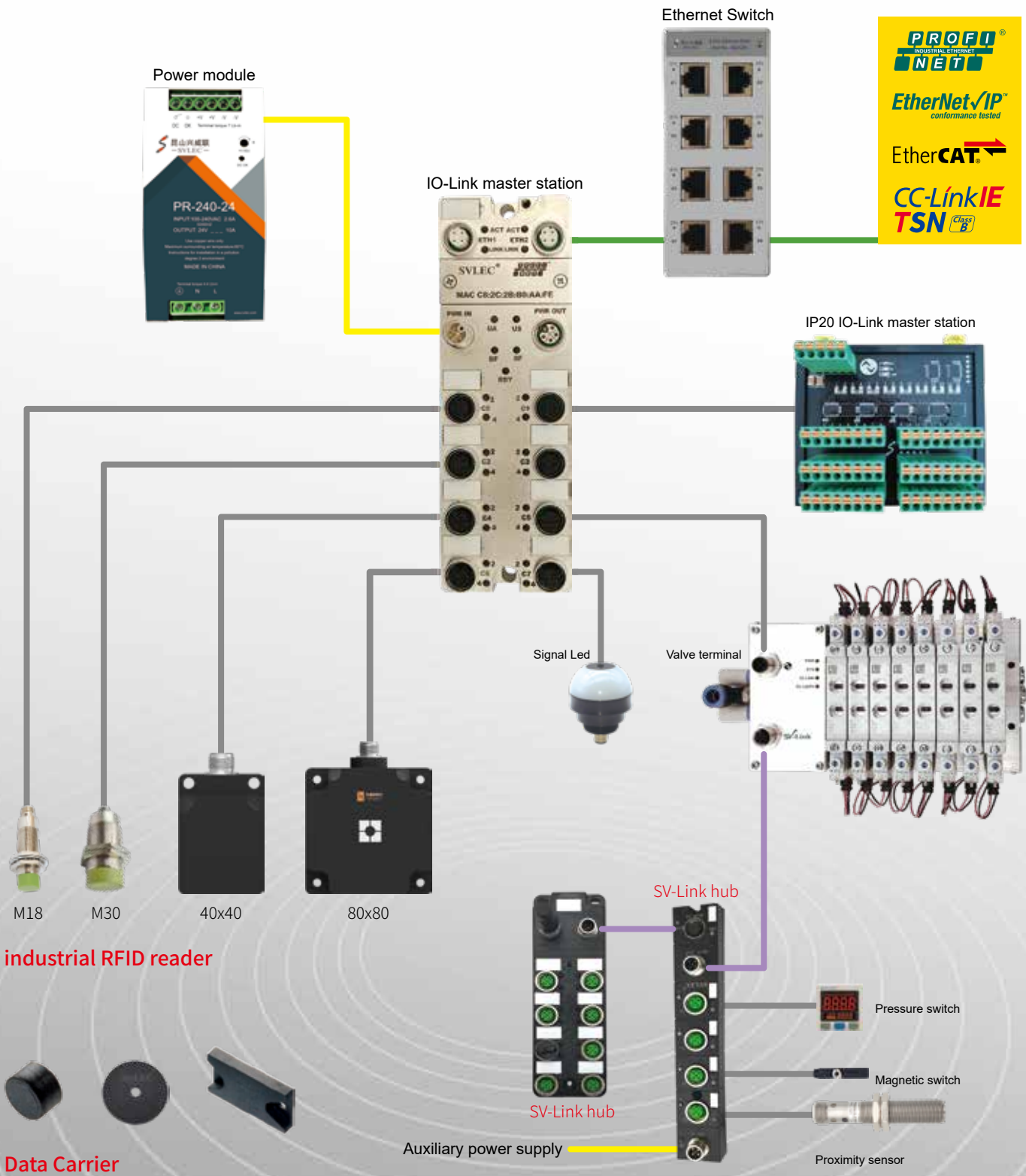

Product dimensional drawing

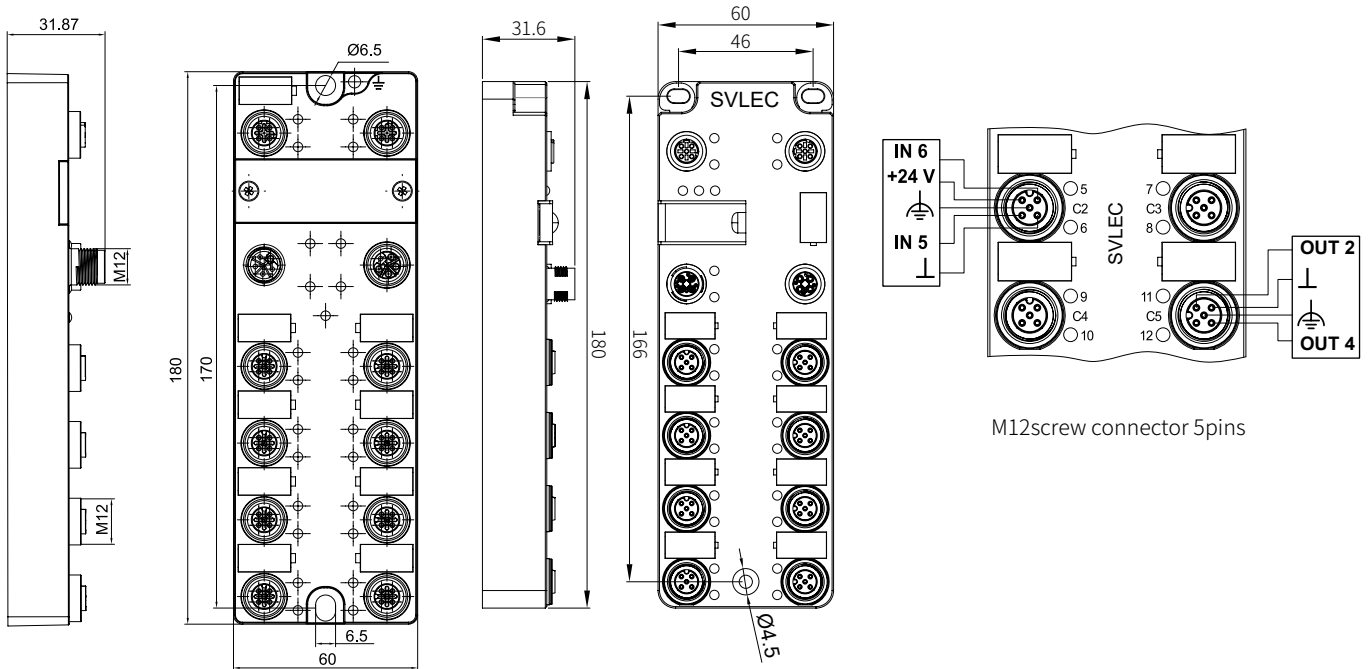

M12 metal module dimensions

M12 Industrial grade plastic module dimensions

Benefits

SVLEC provides fieldbus modules that can meet different bus protocols, whether it is a robust metal housing with extremely high EMC shielding or a reinforced engineering plastic housing, with pluggable connections, diagnostic options and IP67 protection ratings, shock and shock resistance, while maintaining input and output. Sending specific information to the control and module leds, and shutting down only the port affected by the failure, not the entire module, minimizes system downtime - fault finding and problem resolution are faster, and costs are always minimized.

- | | |
|---|---|
| <p>1 Independent channel diagnostics</p> <p>2 Provides diagnostic information that conforms to the appropriate bus standards.</p> <p>3 Diagnostic information is read directly from the user's data area</p> <p>4 Up to 16 digital communications</p> <p>5 Flexible I/O port configuration</p> | <p>6 The operating voltage is completely isolated from the load voltage</p> <p>7 Double-ended valves occupy only one M12 port</p> <p>8 PROFINET The protocol has the fast start function</p> <p>9 High scalability flexibility</p> <p>10 The metal housing is resistant to welding sparks, coolants and lubricants</p> |
|---|---|

Specification	8 x M12
Port Status indicator (Signal status)	LED :Green LED
Port diagnostic indicator (Overload)	LED :Red LED
Total current U_A	≤ 12 A
Total current U_S	≤ 12 A
standard IEC 60529	IP 67 (right connected)
Operating temperature T_a	-25...+60 ° C
Storage temperature	-40...+85 ° C
Fastener	3 pcs open hole
Dimensions (length× width×height)	180×60×31.87 mm







INDUSTRIAL ETHERNET REMOTE DIGITAL I/O MODULE

Advanced diagnostic function

Metal module

Digital quantity



Signal type		16DI/16DO	16 DIX (PNP/NPN) ^{Note 1}	16 DO	16 DOH (2A)
	Type	PNM16DP	PNM16DIX	PNM16DO	PNM16DOH
	Part No.	302202015	104305015	202205015	202305015
	Type	ECM16DP	ECM16DIX	ECM16DO	ECM16DOH
	Part No.	302202018	104305018	202205018	202305018
	Type	EPM16DP	EPM16DIX	EPM16DO	EPM16DOH
	Part No.	302202016	104305016	202205016	202305016
	Type	OPM16DP	OPM16DIX	OPM16DO	OPM16DOH
	Part No.	302202012	104305012	202205012	202305012
	Type	FBM16DP	FBM16DIX	FBM16DO	FBM16DOH
	Part No.	302202013	104305013	202205013	202305013
	Type	CEM16DP	CEM16DIX	CEM16DO	CEM16DOH
	Part No.	302202017	104305017	202205017	202305017

Technical data	
Rated voltage U_b	18...30 V DC
Function indicator LED	SF/BF/RDY
Port status indicator	Red, Green
Power LED	U_A (Red, Green) U_S (Red, Green)
Network interface	M12, D-code, Female (CC-LinkIE TSN: X-Code, Female)
Power interface	M12, L-Code, 5 pin, max. 16A
Housing Material	Zinc alloy
Degree of protection	IP67
I/O port	
Connector	M12, A Code, Female
I/O Number of ports	8
Input type	PNP
Output type	PNP
Sensor supply current	500 mA
Actuator output current	500 mA 2A
ASDM	
Sensor load open circuit detection	Approved
Sensor load short-circuit detection	Approved
Actuator output point fault diagnosis	Approved

Note 1: The original 16DI (PNP) has been upgraded to 16DIX (PNP/NPN), and the configuration file is different after the upgrade.







INDUSTRIAL ETHERNET REMOTE ANALOG I/O MODULE

Advanced diagnostic function

Metal module

Digital quantity



Signal type		8 channel voltage or current inputs	8 channel voltage or current outputs	8 channels are used for temperature detection
	Type	PNM16AIH	PNM16AOH	PNM16ATH
	Part No.	905205015	935205015	925205015
EtherCAT 	Type	ECM16AIH	ECM16AOH	ECM16ATH
	Part No.	905205018	935205018	925205018
	Type	EPM16AIH	EPM16AOH	EPM16ATH
	Part No.	905205016	935205016	925205016
	Type	OPM16AIH	OPM16AOH	OPM16ATH
	Part No.	905205012	935205012	925205012
	Type	FBM16AIH	FBM16AOH	FBM16ATH
	Part No.	905205013	935205013	925205013
	Type	CEM16AIH	CEM16AOH	CEM16ATH
	Part No.	905205017	935205017	925205017

Technical data				
Rated voltage U_b	18...30 V DC			
Function indicator LED	SF/BF/RDY			
Port status indicator	Red, Green			
Power light	U_A (Red, Green) U_S (Red, Green)			
Network port	M12, D-code, Female (CC-Link IE TSN: X-Code, Female)			
Power interface	M12, L-Code, 5 pin, max. 16A			
Housing material	Zinc alloy			
Degree of protection	IP67			
I/O Port				
Connector	M12, A code, Female			
I/O Number	8			
Sensor type	/			PT100,PT1000, Thermocouple
input range	Voltage: $\pm 10V$ DC, 0-10V DC; Current: 0-20mA, 4-20mA	/		
output range	/	Voltage $\pm 10V$ DC, 0-10V DC; Current 0-20mA, 4-20mA	/	
Voltage mode input resistor	Approx. 1M Ω , differential input		/	
Load	Current mode: Approx. 300M Ω , differential input	Voltage mode: min. 500 Ω ; Current mode: max. 500 Ω	/	
Resolution	15 bit + sign bit			
Precision	$\pm 0.5\%$			
ASDM				
Open circuit detection	Approved			
Short-circuit overload detectir	Approved			
Undervoltage detection	Approved			

IO-Link Module



IO-Link is the world's first standardized cross-vendor IO technology (IEC 61131-9), and IO-Link is not just another Fieldbus. IO-Link is an open standard serial communication service that allows bidirectional exchange of data from Approved IO-Link's sensors and devices to connect to the master station. Its communication can be extended from the control layer to the lowest automation layer, all with Approved IO-Link's sensors and devices can be integrated into almost any Fieldbus or in an automated system.



More information please visit
www.svlec.com

IO-Link MODULE

1 master module can connect 8 slaves and each slave module can connect 8 expansion modules

IO-Link is to control the field sensor signals and actuator signals of different manufacturers through communication with the field controller. The benefit lies in making different manufacturers of signal acquisition devices easily compatible. At the same time, IO LINK can save device information, so that the previous parameters can be automatically downloaded when the device is replaced, so as to facilitate maintenance. Each IO-Link device has an IODD (IO device Description). This is a device description file that contains the manufacturer, product number, features, etc. Users can easily read this information and process it further. Each device can be uniquely identified by its IODD and internal device ID.

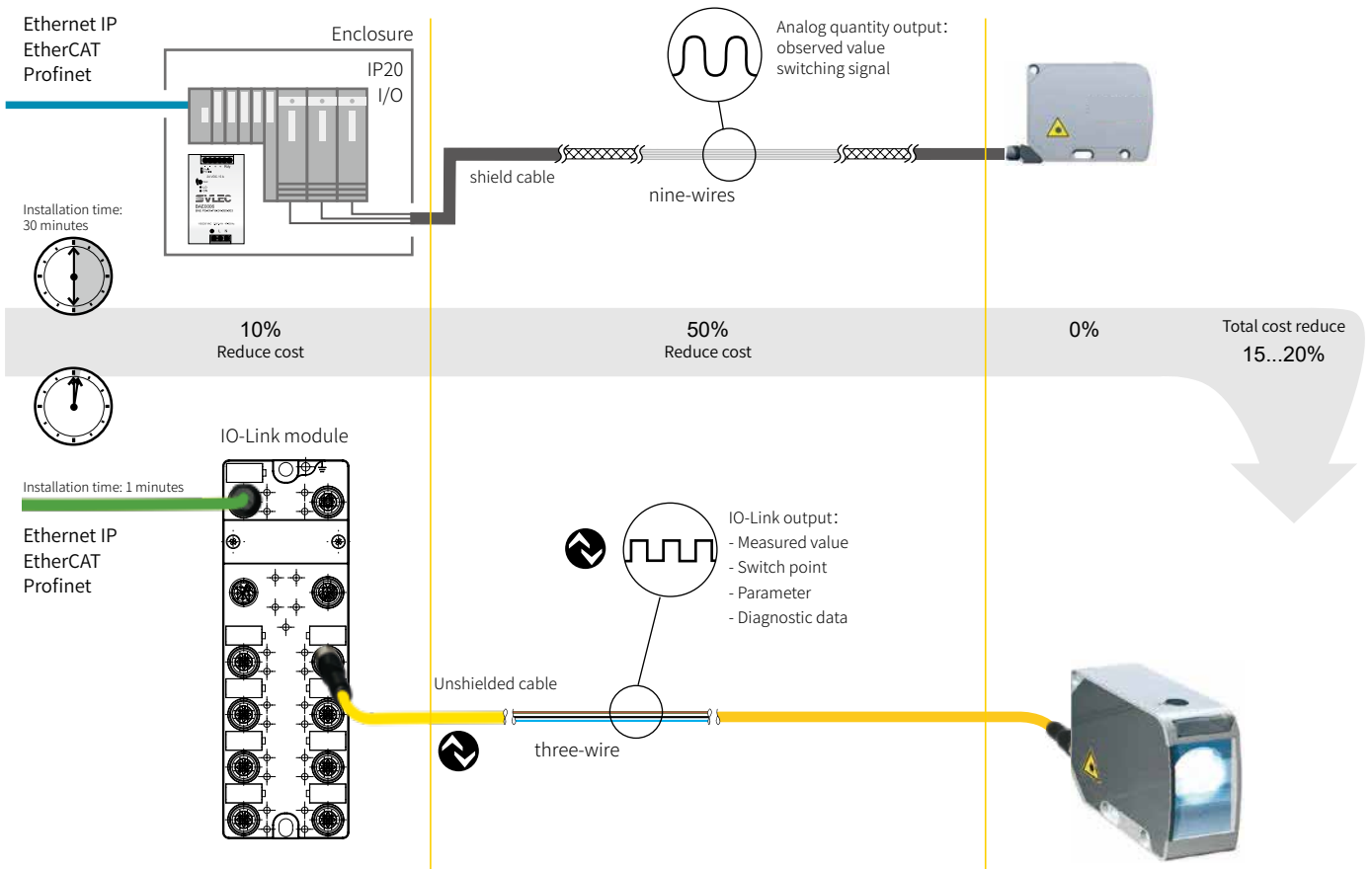
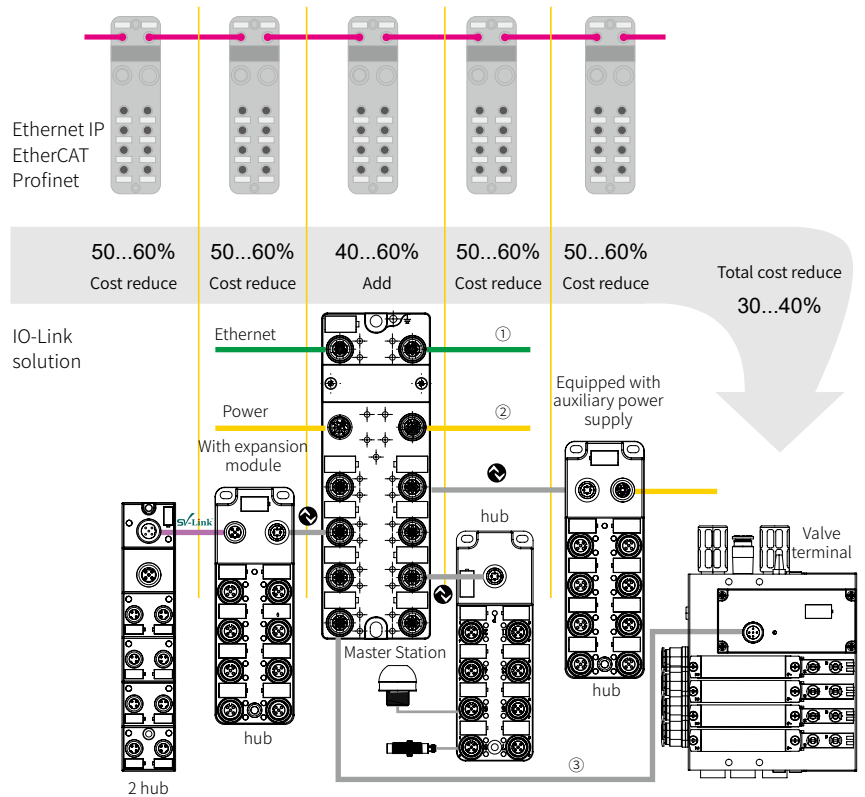

IO-Link MODULE

Product dimensional drawing

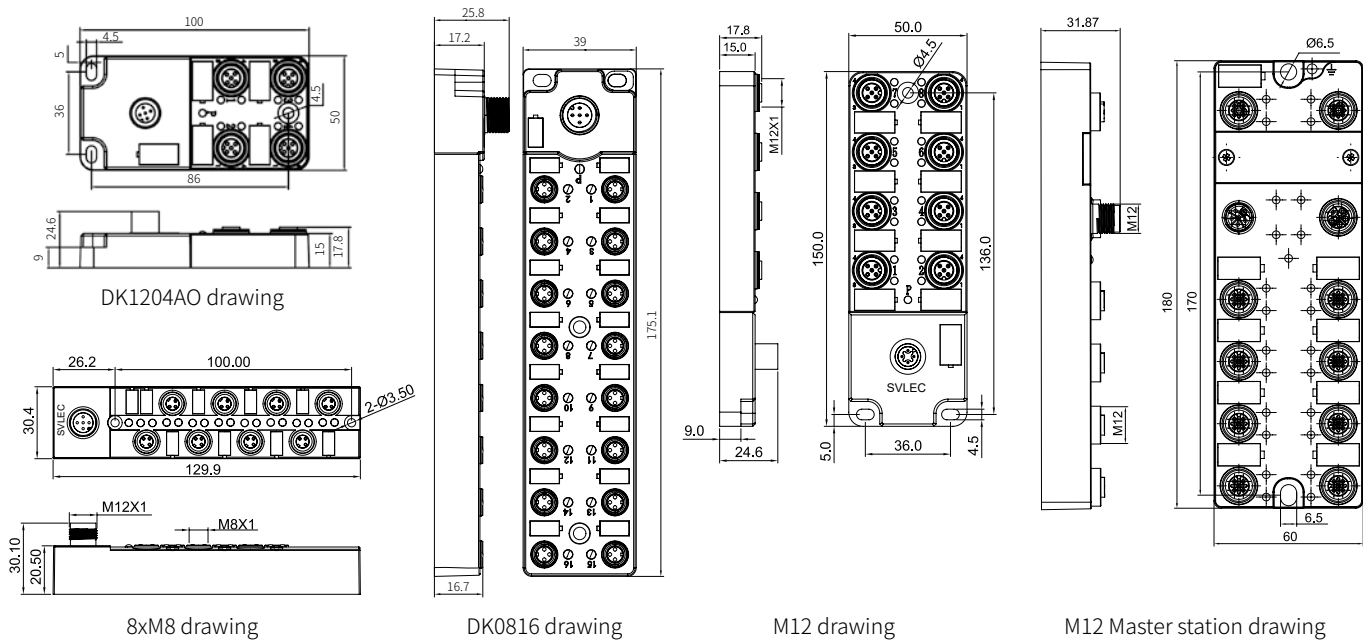

IO-Link Benefits

1 Standardize and reduce wiring requirements

IO-Link is designed to enable simple compatibility of field signal acquisition devices from different manufacturers, using a cost effective unshielded 3-core standard cable connection, while also approving a master-slave configuration with passive connection points, which further reduces wiring requirements.

2 Increase data availability

Access to sensor data facilitates the smooth operation of the equipment, optimizes the maintenance schedule of the equipment, thereby saving costs and reducing the risk of equipment downtime, and three main data forms are available through IO-Link communication

- a: The process data that the device reads and sends to the master station.
- b: The service data of the sensor itself, such as its parameter value, model, series number, device description, etc. The service data can be written to the device or read from the device acyclic.
- c: Event data transmitted from the IO-Link device to the master device, such as notifications of error messages, maintenance warnings, etc.

3 Remote configuration and monitoring

Through the control system software to read and change equipment parameters, to achieve rapid configuration and debugging, monitor sensor output, receive real-time status alarm, remote adjustment of sensor Settings, timely identification and solution of sensor level problems.

4 Simple equipment replacement

IO Link has a data storage function that can save device information, so that the previous parameters can be automatically downloaded when the device is replaced, and the old sensor parameters can be imported into the new sensor for seamless replacement, so that the new device is up and running as soon as possible.

5 Netdiag

IO Link provides users with the errors and health of each device, which means users can see not only what the sensor is doing but also how well it is performing, being able to easily identify sensor failures and diagnose problems.

Technical data	Master Station
Port status indicator	Green LED indicator
Port diagnostic indicator LED (overload)	Red LED indicator
Total current U_A	≤ 12 A
Total current U_S	≤ 12 A
IEC 60529 Degree protection IEC 60529 standard	IP 67 (Correctly connected)
Working Temperature T_s	-25...+60 ° C
Storage temperature	-30...+70 ° C
Fastener	3 mounting holes
Dimensions (length× width× height)	180×60×31.87 mm
Housing Material	Zinc Alloy

IO-Link MASTER STATION MODULE

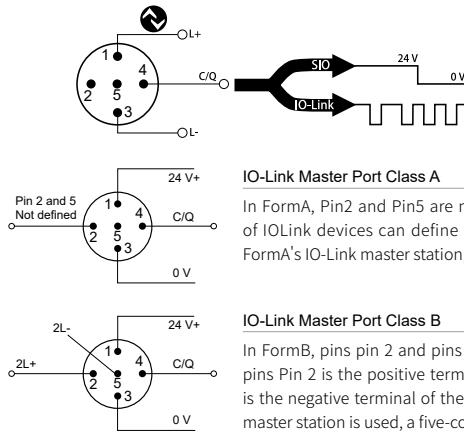





IO-Link Master Port Class A

In FormA, Pin2 and Pin5 are not clearly defined. Generally, manufacturers of IO-Link devices can define their own as required. When connecting to FormA's IO-Link master station, a three-core cable can be used.

IO-Link Master Port Class B

In FormB, pins pin 2 and pins Pin 5 are used to provide additional power: pins Pin 2 is the positive terminal of the power supply, and pins Pin 5 is the negative terminal of the power supply. Link FormB, when the IO-Link master station is used, a five-core cable is used.



Signal type		4 Class A+4 Class B	8 Class A
	Type	PNM16DK	PNM16DN
	Part No.	508105015	502105015
	Type	EPM16DK	EPM16DN
	Part No.	508105016	502105016
	Type	ECM16DK	ECM16DN
	Part No.	508105018	502105018
	Type	OPM16DK	OPM16DN
	Part No.	508105012	502105012
	Type	FBM16DK	FBM16DN
	Part No.	508105013	502105013
Technical data			
Rated working voltage UB		18...30 V DC	
Function indicator LED		SF/BF/RDY	
Module status indicator: Mod LED		Yes	
Status LED: Net LED		Yes	
Port status indicator		Red, Green	
Network port		M12, D-Code, Female	
Power interface		M12, L-Code, 5 pins	
Connection: I/O port		M12, A Code, Female	
I/O Number of I/O ports		8	
Input quantity		Max 8 PNP input	Max 16 PNP input
Output		Max 12 PNP output	Max 16 PNP output
Input / output		yes	
Maximum load current, sensor/channel		2 A	
Max output load current		2 A	
IO-Link 1.1			
IO-Link Port		4 Class A + 4 Class B	8 Class A
Operating mode (3 wire)		SIO, COM 1, COM 2, COM 3	
Indicator LED: Communication		Green LED indicator	
Error		Red LED indicator LED	
IO-Link Max current of the device		2 A	

IO-Link M8 SLAVE MODULE

Single channel fast, detailed diagnostics

The lightweight, small size and single channel monitoring of the M8 sensor hub with an IO Link port means that all the time - and cost-saving benefits of IO-Link, including easy installation, central configuration and integrated diagnostics, are enhanced by this additional technical performance. This single-channel monitoring feature provides detailed diagnostic results extremely quickly. This single channel monitoring feature is dedicated to short circuit, port overload, and cable break diagnostics for each single channel start port. Transmit diagnostic data along with process data to detect redundant non-cyclic services.



	Sub-station		
Signal type	8×DI	16×DI	8×DO
Type	DK0808DI	DK0816DI	DK0808DO
Part No.	102000019	102000020	102000119
Technical data			
Rated working voltage UB	18...30 V DC		
Power start indicator	Green LED		
Connection: I/O port	M8, 3 pins, Female		
Connection: I/O Link port	M12, A Code, male		
I/O Number of I/O ports	8	16	8
Input quantity	8 ↑ PNP input	16 ↑ PNP/NPN input	8 ↑ PNP output
Input status LED	Green LED indicator		
Sensor power supply	500mA		
Actuator power supply	500mA		
Total current UT	Max. 2 A		
Degree protection IEC 60529	IP 67 (Correctly connected)		
Working Temperature Ta	-25...+60 ° C		
Storage temperature	-30...+70 ° C		
Weight	103 g	131 g	113 g
volume (L×W×H)	129.5×30×23.7 mm	175.1×39×25.8 mm	129.5×30.4×30.1 mm
Fastener	2 Mounting holes		
Housing Material	PA		
IO-Link			
IO-Link port	1× module		
work pattern	COM 2		
IO-Link cable	3 pins		
IO-Link Processing data length	1 byte input	2 byte input	1 byte output
Indicator LED: Communication	Green LED		
Error	Red LED indicator LED		

Note: All Yes modules include two screw plugs and a label set.

IO-Link M12 DIGITAL QUANTITY SLAVE MODULE

As an interface for interchangeable tools, their benefits are clear:

- Use unshielded 3 - or 4-core cables for quick installation and low cost.
- Fast and reliable format changes
- Provide data centrally for continuous process control
- Tools can be easily replaced with hubs and data
- Quick settings
- The Pass controller easily encodes new tools

Optional sensor hubs from Xingweilian reduce costs, simplify work and shorten idle cycles while ensuring maximum efficiency

Equipped with auxiliary power supply
DK1208DO
DK1208DS

Extended module
DK1208DX



Sub-station

Signal type	16DI	16DI/16DO	16DI/16DO	16DI/16DO	16DO	16DO	16DI/16DO
Form	PNP	PNP	NPN	PNP	PNP	PNP	PNP
Type	DK1208DI	DK1208DP	DK1208DPN	DK1208DE	DK1208DO	DK1208DS	DK1208DX
Part No.	104001012	302001006	302001016	302001007	256001013	256001012	302001008
IO-Link	CLASS A	CLASS A	CLASS A	CLASS A	CLASS A	CLASS A	CLASS A
Technical data							
US Power supply	IO-Link 端口 24V						
Actuator power supply mode	/	IO-Link ports 24V		IO-Link PIN2	Pass port T Coded		IO-Link PIN2
Scalable	/	No		Yes			
Scalable	No						By SV-Link
Sensor power supply	500 mA				/		500 mA
Actuator power supply	/	500 mA			2 A	500 mA	500 mA
Rated working voltage UB	18...30 V DC						
IO-Link RUN	Green LED						
Power start indicator	Green LED						
Connection: I/O Link	M12, A Code, male						
Connection: port	M12, A Code, Female						
I/O Number of I/O ports	8						
Channel monitoring	Yes						
IO-Link encodeable	Yes						
Port status indicator	Green /Red LED						
Total current UT	2.6 A				12 A		2.6 A
IEC 60529	IP 67 (Correctly connected)						
Working Temperature Ta	-25...+60 ° C						
Storage temperature	-30...+70 ° C						
Fastener	3 Mounting holes						
volume (L×W×H)	150×50×18 mm						
Housing Material	PA						
IO-Link							
IO-Link cable	3 core	3 core		4 core	3 core		4 core
IO-Link Process data bytes	2 byte input	2 byte input +2 byte output			2 byte output		2DI+2DO+ extent
Indicator LED: Communication	Green LED						
Error	Red LED indicator LED						

Note: All Yes modules include two screw plugs and a label set.

IO-Link M12 ANALOG SLAVE STATION

- Use unshielded 3 - or 4-core cables for quick installation and low cost.
- Fast and reliable format changes
- Provide data centrally for continuous process control.
- Tools can be easily replaced with hubs and data
- Fast settings
- The Pass controller easily encodes new tools

The optional sensor hub from Xingweilian costs less and simplifies work And shorten idle periods while ensuring maximum efficiency.



Signal type	8 way Voltage/Current inputs	8 way temperature inputs	4 way output
Type	DK1208AIH	DK1208ATH	DK1204AO
Part No.	302003007	302003003	302002008
IO-Link	CLASS A	CLASS A	CLASS B
Technical data			
US power supply	IO-Link 24V		
Sensor power supply	500 mA		
Rated working voltage UB	18...30 V DC		
IO-Link RUN	Green LED		
Power start indicator	Green LED		
Connection: I/O Link	M12, A Code, male		
Connection: I/O port	M12, A Code, Female		
I/O Number	8		4
Input	±10VDC,0-10V DC; 0-20mA, 4-20mA, ±20mA	Pt100, Pt1000, thermocouple	/
Output	/	/	±10V DC,0-10V DC; 0-20mA, 4-20mA, ±20mA
Precision	0.5%		
IO-Link encodeable	Yes		
Port status indicator	Green / Red LED		
Total current UT	2.6 A		
IEC 60529	IP 67 (Correctly connected)		
Working Temperature Ta	-25...+60 ° C		
storage temperature	-30...+70 ° C		
Fastener	3 Mounting holes		
Volume (L×W×H)	150×50×18 mm		100×50×17.8 mm
Housing Material	PA		
IO-Link			
IO-Link cable	3 pins		5 pins
IO-Link Process data bytes	18 Input		2 Input + 8 Output
Indicator :Communication	Green LED		
Error	Red LED		

Note: All Yes modules include two screw plugs and a label set.

IO-Link M12 ANALOG SLAVE STATION

- Use unshielded 3 - or 4-core cables for quick installation and low cost.
- Fast and reliable format changes
- Provide data centrally for continuous process control.
- Tools can be easily replaced with hubs and data
- Fast settings
- The Pass controller easily encodes new tools

The optional sensor hub from Xingweilian costs less and simplifies work And shorten idle periods while ensuring maximum efficiency.



IO-Link		
Signal type	1 Analog input	2 Temperature inputs
Type	DK1201AI	DK1202AT
Part No.	302002005	302002004
IO-Link	CLASS A	CLASS A
Technical data		
US power supply	IO-Link 24V	
Sensor power supply	250 mA	/
Rated working voltage UB	18...30 V DC	
IO-Link RUN	Green LED	
Power start indicator	Green LED	
Connection: I/O Link	M12, A Code, male	
Connection: I/O port	M12, A Code, Female	
I/O Number	1	2
Input	±10VDC,0-10V DC; 0-20mA, 4-20mA, ±20mA; Pt100, Pt1000,thermocouple	Pt100, Pt1000, thermocouple
Precision	0.5%	
IO-Link encodeable	Yes	
Port status indicator	Green /Red LED	
Total current UT	2.6 A	
IEC 60529	IP 67 (Correctly connected)	
Working Temperature Ta	-25...+60 ° C	
storage temperature	-30...+70 ° C	
Fastener	2 Mounting holes	
Volume (L×W×H)	70×36×17.25 mm	70×49.8×17.25 mm
Housing Material	TPU	
IO-Link		
IO-Link cable	3 pins	
IO-Link Process data bytes	4 Input	6 Input
Indicator LED: Communication	Green LED	
Error	Red LED	

Note: All Yes modules include two screw plugs and a label set.

DK1201AI

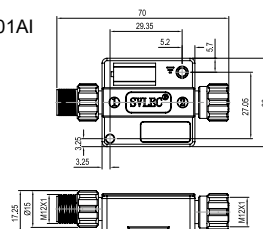

DK1202AT

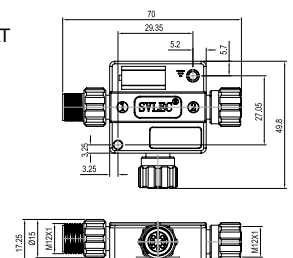

IO-Link SLAVE -IP20

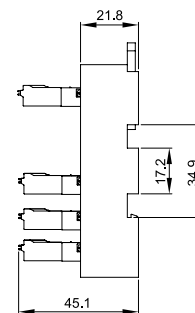
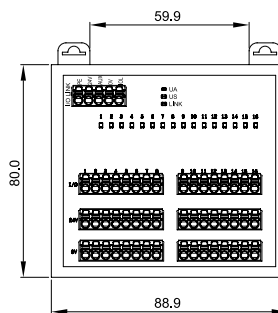

Ordering information	16 x DI	32 x DI	16 x DI/DO	16 x DI/DO
Type	DKT16DI	DKT32DI	DKT16DPN	DKT16DP
Part No.	104002012	104002013	302002001	302002002
Technical data				
Rated working voltage U_B	18...30 V DC			
IO-Link RUN	Green LED			
Power start indicator	Green LED			
Connection IO-Link	M12, 3, A Coded, male		M12, 4, A Coded, male	
Connection US	Spring plate terminal, insert type			
Connection UA	Spring plate terminal, insert type			
Connection : I/O port	Spring plate terminal, insert type			
I/O Form	PNP		NPN	PNP
I/O Number of I/O ports	16	32	16	
Input quantity	Max. 16	Max. 32	Max. 16	
Output qty	/		Max. 16	
Us per channel	500 mA			
Ua per channel	500 mA			
Port status indicator	Green LED			
Total current UT	< 2 A			
Total current UO	< 2 A			
IEC 60529	IP20			
Working Temperature	-25...+70 °C			
Storage temperature	-25...+85 °C			
Installation	DIN35			
Volume (LxWxH)	88.9×80×45.1 mm			
IO-Link				
IO-Link ports qty	1 x module			
IO-Link cable	3 pin		4 pin	
Max cycle time	3 ms			
IO-Link data length	2 byte Input		2 byte for Input / 2 byte for Output	
Indicator: Communication	Green LED			
Error	Red LED indicator			

IO-LINK VALVE TERMINAL ADAPTER

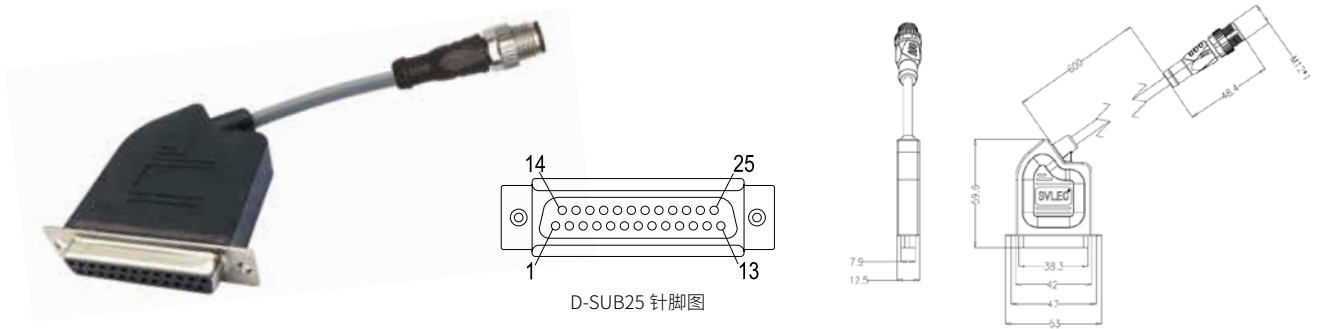

IO-Link	CLASS A	CLASS A
Type	DKF25-A	DKF25-B
Part No.	301002001	301002002
Technical data		
Us power supply	IO-Link 24V	
Valve power supply	PIN 2	
Max number of coils	24	
Suitable for :	FESTO	SMC
Rated working voltage UB	18...30 V DC	
IO-Link RUN	Green LED	
Power start indicator	Green LED	
Connection: I/O Link	M12, A Code, Male	
Connection: I/O Port	D-SUB25, Female	
Total current UT	2.6 A	
Working Temperature Ta	-25...+60 ° C	
Storage temperature	-30...+70 ° C	
Fastener	2 Mounting holes	
Size (L × W × H)	70 × 36 × 17.25 mm	
Housing material	TPU	
IO-Link		
IO-Link cable	4 Pins	
IO-Link process data	3 Output	
Indicator LED : Communication	Green LED	
Error	Red LED	







Note: The cable length can be customized, with a default length of 0.6 meters.







Output signal

DKF25-A														
D-SUB25 layout	PIN1	PIN2	PIN3	PIN4	PIN5	PIN6	PIN7	PIN8	PIN9	PIN10	PIN11	PIN12	PIN13	PIN14
Completed	Valve 1_A	Valve 1_B	Valve 2_A	Valve 2_B	Valve 3_A	Valve 3_B	Valve 4_A	Valve 4_B	Valve 5_A	Valve 5_B	Valve 6_A	Valve 6_B	Valve 7_A	Valve 7_B
D-SUB25 layout	PIN15	PIN16	PIN17	PIN18	PIN19	PIN20	PIN21	PIN22	PIN23	PIN24	PIN25			
Completed	Valve 8_A	Valve 8_B	Valve 9_A	Valve 9_B	Valve 10_A	Valve 10_B	Valve 11_A	Valve 11_B	Valve 12_A	Valve 12_B	GND			
DKF25-B														
D-SUB25 layout	PIN1	PIN2	PIN3	PIN4	PIN5	PIN6	PIN7	PIN8	PIN9	PIN10	PIN11	PIN12	PIN13	PIN14
Completed	Valve 1_A	Valve 2_A	Valve 3_A	Valve 4_A	Valve 5_A	Valve 6_A	Valve 7_A	Valve 8_A	Valve 9_A	Valve 10_A	Valve 11_A	Valve 12_A	GND	Valve 1_B
D-SUB25 layout	PIN15	PIN16	PIN17	PIN18	PIN19	PIN20	PIN21	PIN22	PIN23	PIN24	PIN25			
Completed	Valve 2_B	Valve 3_B	Valve 4_B	Valve 5_B	Valve 6_B	Valve 7_B	Valve 8_B	Valve 9_B	Valve 10_B	Valve 11_B	Valve 12_B			





CONFIGURATION PRODUCT

■ Profinet/EtherCAT/EtherNetIP/CC-link Field Basic/Modbus/IO-LINK

		M12 4pin D-code	M12 4pin D-code	M12 to RJ45 4pin	Connector Shielded 4pin fielded-wireable (Wire gauge) Part No.:
PNM/ECM/EPM/FBM/OPM ①					 914521 (22-26AWG)
Profinet (2x2x24AWG)	Fixed	914541-790-XXXX	944511-790-XXXX	944711-790-XXXX	 999051 (22-24AWG) 999181 (24-26AWG)
	Flex	914541-796-XXXX	944511-796-XXXX	944711-796-XXXX	
CAT 5e. (2x2x24AWG)	Fixed	914541-795-XXXX	944511-795-XXXX	944711-795-XXXX	 999061 (22-24AWG) 999071 (24-26AWG)
	Flex	914541-797-XXXX	944511-797-XXXX	944711-797-XXXX	
CAT 5e. (2x2x26AWG)	Fixed	914541-791-XXXX	944511-791-XXXX	944711-791-XXXX	 999061 (22-24AWG) 999071 (24-26AWG)
	Flex	914541-793-XXXX	944511-793-XXXX	944711-793-XXXX	

		M12 4pin D-code	M12 4pin D-code	M12 to RJ45 4pin	Connector Shielded 4pin fielded-wireable (Wire gauge) Part No.:
PNM/ECM/EPM/FBM/OPM ①					 914581
Profinet (2x2x24AWG)	Fixed	914561-790-XXXX	944561-790-XXXX	944761-790-XXXX	M12 Female cap
	Flex	914561-796-XXXX	944561-796-XXXX	944761-796-XXXX	
CAT 5e. (2x2x24AWG)	Fixed	914561-795-XXXX	944561-795-XXXX	944761-795-XXXX	 996050
	Flex	914561-797-XXXX	944561-797-XXXX	944761-797-XXXX	
CAT 5e. (2x2x26AWG)	Fixed	914561-791-XXXX	944561-791-XXXX	944761-791-XXXX	 996050
	Flex	914561-793-XXXX	944561-793-XXXX	944761-793-XXXX	

■ CC-LinkIE TSN



		M12 8pin X-code	M12 8pin X-code	M12 to RJ45 8pin X-code	M12 8pin X-code
CEM ①					 917941
CAT 6A. 4x(2x26AWG)	Fixed	917484-789-XXXX	917485-789-XXXX	948811-789-XXXX	 917941
	Flex	917484-779-XXXX	917485-779-XXXX	948811-779-XXXX	

■ Profinet/EtherCAT/EtherNetIP/CC-link Field Basic/Modbus/IO-LINK

		M12 5pin L-code	M12 5pin L-code	M12 5pin L-code	M12 5pin L-code	M12 5pin L-code
PNM/ECM/EPM/CEM/FBM/OPM ②						
5x1.5mm ²	Fixed	912554-961-XXXX	912454-961-XXXX	942045-961-XXXX	1.5mm ² 912743	1.5mm ² 912952
	Flex	912554-962-XXXX	912454-962-XXXX	942045-962-XXXX		

		M12 5pin L-code	M12 5pin L-code	M12 5pin L-code	M12 5pin L-code	M12 5pin L-code
PNM/ECM/EPM/CEM/FBM/OPM ②						
5x1.5mm ²	Fixed	912555-961-XXXX	912455-961-XXXX	942046-961-XXXX	2.5mm ² 912749	2.5mm ² 912972
	Flex	912555-962-XXXX	912455-962-XXXX	942046-962-XXXX		

■ IO-LINK From master station to slave station

		M12 3pin A-code	M12 4pin A-code	M12 5pin A-code	M12 5pin A-code	M12 5pin A-code
DK ③						
0.34mm ²	Fixed	940001-613-XXXX	940021-614-XXXX	940041-615-XXXX	912721	912921
	Flex	940001-633-XXXX	940021-634-XXXX	940041-635-XXXX		

IO lines and accessories are on pages A1.6.7-A1.6.10



EtherCAT®

COMPACT I/O MODULE



High performance
compact structure
waterproof design



More information please visit
www.svlcc.com

COMPACT I/O MODULE

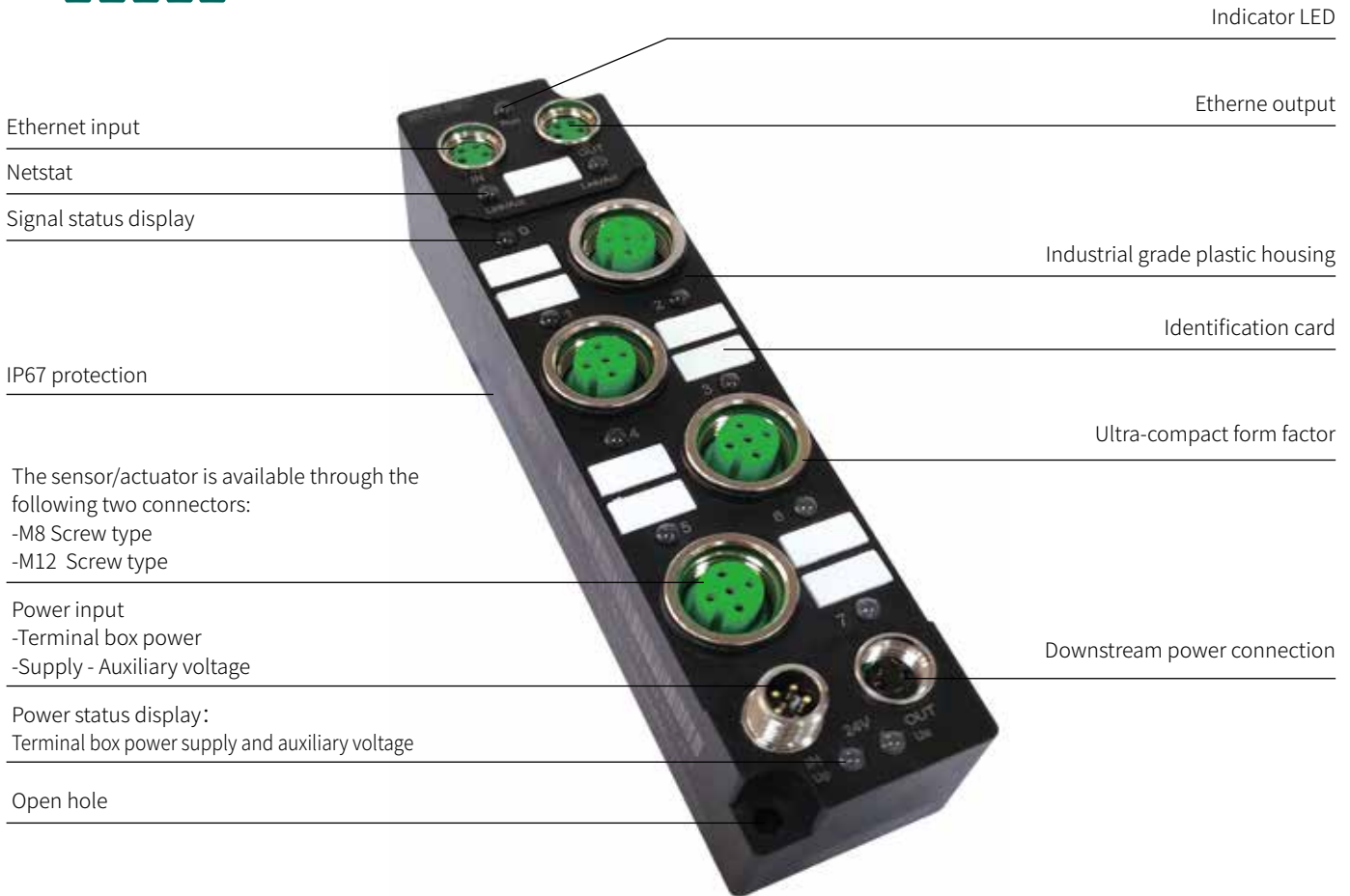

Ethernet input

Netstat

Signal status display

IP67 protection

The sensor/actuator is available through the following two connectors:

- M8 Screw type
- M12 Screw type

Power input

- Terminal box power
- Supply - Auxiliary voltage

Power status display:

Terminal box power supply and auxiliary voltage

Open hole

Indicator LED

Ethernet output

Industrial grade plastic housing

Identification card

Ultra-compact form factor

Downstream power connection

Compact I/O Module Benefits

1 Tight and durable

Robust construction allows the fieldbus terminal box to be mounted directly on the machine, eliminating the need for control cabinets and dedicated junction boxes.

2 Sealed

The terminal box is all cast out of resin with a Degree protection of IP 67 and is ideal for wet, dirty and dusty conditions.

3 Compact appearance

The outline size of the terminal box is very small, so it is suitable to install them in places with little reserved space.

4 Easy-link

With pre-assembled cables, wiring between the I/O terminal box bus and the signal is simple, minimizing wiring errors and speeding up system installation.

5 Increase flexibility

In addition to pre-assembled cables, connectors and cables suitable for field wiring are available to maximize the flexibility of installation construction.

6 Economical efficiency

A variety of hybrid I/O terminal boxes and fine granularity in signal processing reduce system costs - you only need to buy what you really need. Since the number of channels per I/O terminal box is multiplied, the 16-channel series also provides significant time and cost savings in fieldbus and power wiring.

7 Complete product range

Due to the wide range of signal forms that can be processed by the terminal box provided by SVLEC, sensors and actuators of almost any types can be connected.

8 Install in place

Sensors and actuators can be connected using screw type connectors (M8 or M12). screw type connectors have the advantage of high draw resistance.

9 Suitable for extreme weather conditions

Most I/O terminal boxes are available for -25... +60 °C (storage temperature -40... +85 °C).

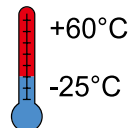

COMPACT I/O MODULE

Product dimensional drawing

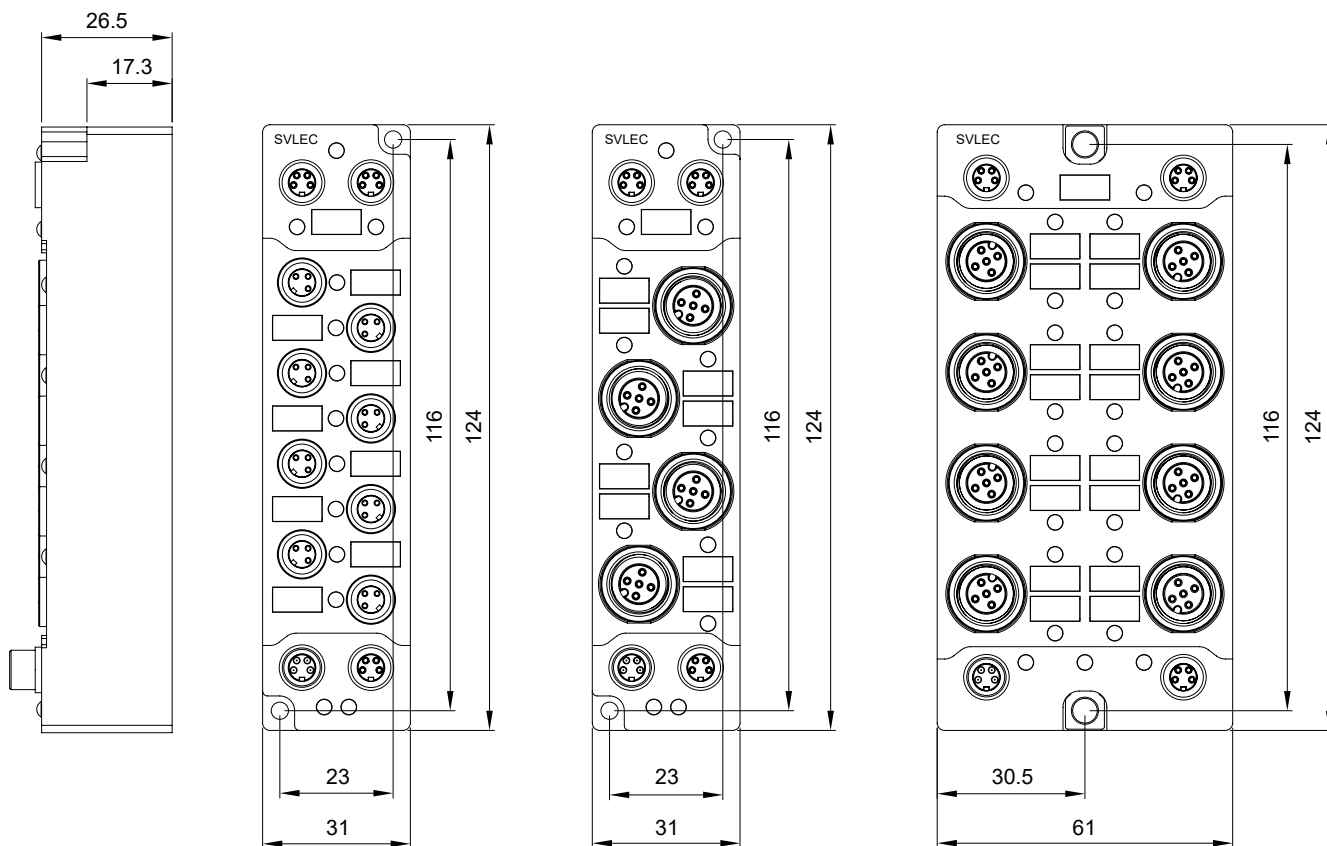

8 x M8 Drawing

4 x M12 Drawing

8 x M12 Drawing

Specification	8 x M8 4 x M12	8 x M12
Overall dimensions (W × H × D)	30 × 123 × 26.5 mm	60 × 123 × 26.5 mm
Material	PC	PC
Installation	2 3.5 mm diameter mounting hole for M3	2 5 mm diameter mounting hole for M4
Working Temperature	-25...+60 ° C	
Storage temperature	-40...+85 ° C	
Vibration/impact resistance	EN 60068-2-6/EN 60068-2-27 Standard	
EMC	EN 61000-6-2/EN 61000-6-4 Standard	
Degree protection	IP 67	
Max current	IMAX = 4 A	

COMPACT I/O MODULE

Basic diagnosis

Digital



8xM8



4xM12

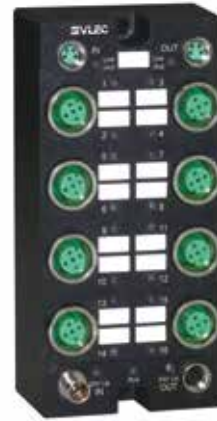











8xM12

Protocol	EtherCAT®			PROFINET® PROFIBUS DP/RS485	
Ordering information	8 DI	8 DI	16 DI	8 DI	8 DI
PNP Type	EC0808DI	EC1208DI	EC1216DI	PN0808DI	PN1208DI
PNP Part No.	500002001	500002002	500002003	500002011	500002012
NPN Type	EC0808DIN	EC1208DIN	EC1216DIN	PN0808DIN	PN1208DIN
NPN Part No.	500002101	500002102	500002103	500002111	500002112
Technical data					
IO port	8xM8	4xM12	8xM12	8xM8	4xM12
Standard	EN 61131-2, type 1/3				
Input filter	1.0 ms				
Input quantity	8		16	8	
Supply current	500mA				
Nominal voltage	24 V DC (-15% / + 20%)				
Services	Ether CAT			Profinet	
Bus Interface	2 x M8 Female, Shielded , Screw type				
Sensor power supply	Powered by control voltage, maximum total 0.5A, Yes short-circuit protection				
U _s Current consumption(without sensor)	50 mA			100 mA	
Ordering information	8 DO	8 DO	16 DO	8 DO	8 DO
PNP Type	EC0808DO	EC1208DO	EC1216DO	PN0808DO	PN1208DO
PNP Part No.	500001001	500001002	500001003	500001011	500001012
NPN Type	EC0808DON	EC1208DON	EC1216DON	PN0808DON	PN1208DON
NPN Part No.	500001101	500001102	500001103	500001111	500001112
Technical data					
IO port	8xM8	4xM12	8xM12	8xM8	4xM12
Load	Resistance-type Load、 Inductance Type Load、 electric Load				
Max output current	Per channel 0.5 A (Short circuit protection)			0.5A per channel, respectively with short circuit protection function, Total current Max. 4A	
Output qty	8			8	
Rated Voltage	24 V DC (-15% / + 20%)		16		
U _s Current consumption(without sensor)	50 mA				
Short-circuit current	1.5 A			100 mA	
Electric isolation	500 V				





CONFIGURATION PRODUCT

Profinet & EtherCAT

EC/PN		M8 4pin A-code	M8 4pin A-code	M12 to RJ45 4pin	Connector Shielded 4pin fielded-wireable (Wire gauge) Part No.:
EC/PN					 908651
Profinet (2x2x22AWG)	Fixed	989701-794-XXXX	988701-794-XXXX	934911-794-XXXX	 999051 (22-24AWG) 999181 (24-26AWG)
	Flex	989701-796-XXXX	988701-796-XXXX	934911-796-XXXX	
CAT 5e. (2x2x24AWG)	Fixed	989701-795-XXXX	988701-795-XXXX	934911-795-XXXX	 999061 (22-24AWG) 999071 (24-26AWG)
	Flex	989701-797-XXXX	988701-797-XXXX	934911-797-XXXX	
CAT 5e. (2x2x26AWG)	Fixed	989701-791-XXXX	988701-791-XXXX	934911-791-XXXX	 999061 (22-24AWG) 999071 (24-26AWG)
	Flex	989701-793-XXXX	988701-793-XXXX	934911-793-XXXX	

EC/PN		M8 4pin A-code	M8 4pin A-code	M8 to RJ45 4pin	M8 4pin D-code
EC/PN					
Profinet (2x2x22AWG)	Fixed	989721-794-XXXX	988721-794-XXXX	934912-794-XXXX	944901-794-XXXX
	Flex	989721-796-XXXX	988721-796-XXXX	934912-796-XXXX	944901-796-XXXX
CAT 5e. (2x2x24AWG)	Fixed	989721-795-XXXX	988721-795-XXXX	934912-795-XXXX	944901-795-XXXX
	Flex	989721-797-XXXX	988721-797-XXXX	934912-797-XXXX	944901-797-XXXX
CAT 5e. (2x2x26AWG)	Fixed	989721-791-XXXX	988721-791-XXXX	934912-791-XXXX	944901-791-XXXX
	Flex	989721-793-XXXX	988721-793-XXXX	934912-793-XXXX	944901-793-XXXX

Compact plastic module Ethernet power interface

EC/PN		M8 4pin A-code	M8 4pin A-code	M8 4pin A-code	M8 4pin A-code	M8 4pin A-code
EC/PN						
0.25mm ²	Fixed	908011-614-XXXX	908061-614-XXXX	988011-614-XXXX	908611	908631
	Flex	908011-634-XXXX	908061-634-XXXX	988011-614-XXXX		

IO lines and accessories are on pages A1.6.7-A1.6.10

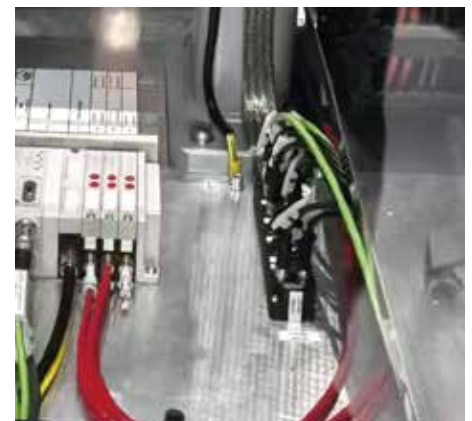

7/8" POWER PORT IO MODULE

- Advanced diagnostic function
- Multi protocol Ethernet protocol
- Visualization of Ethernet Protocol





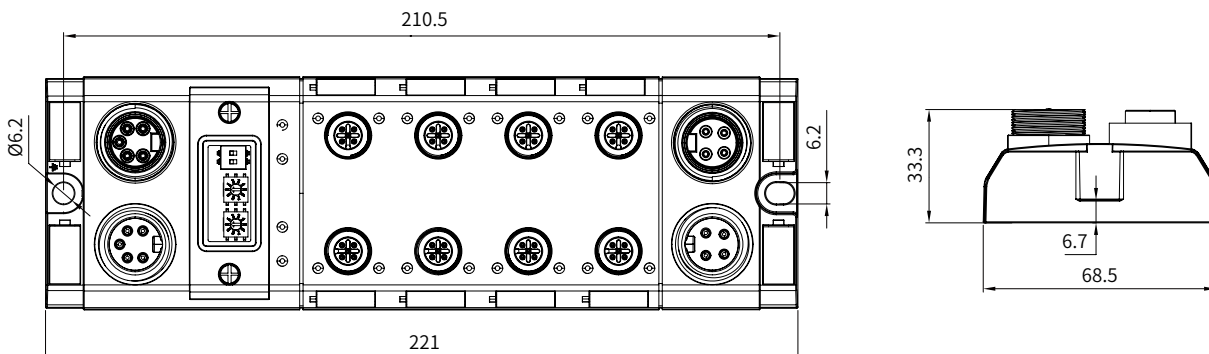







Protocol	DeviceNet			PROFINET	EtherCAT	EtherNet/IP	CC-Link IE	Modbus TCP
Signal type	8DI+8DO	16DI	16DO	16DI/16DO	16DI			
Type	DNU16DM	DNU16DI	DNU16DO	NETU16DP	NETU16DIX			
Part No.	505105017	504105017	502105017	302202101	104205101			
Technical data								
Rated voltage U_b	18...30 V DC			18...30 V DC				
Function indicator LED	MS/NS			ETH/BF/SF/RDY				
Port indicator	Red, Green			Red, Green				
Power light	U_A (Red, Green) U_S (Red, Green)			U_A (Red, Green)				
Network port	7/8", 5 针			M12, D-code, Female				
Power interface	7/8", 4 针, max. 9A			7/8", 5 针, max. 9A				
Housing material	PA			PA				
Degree of protection	IP67			IP67				
I/O Port								
Connector	M12, A Code, Female			M12, A Code, Female				
I/O Number of ports	8			8				
Input type	PNP / NPN		/	PNP	PNP/NPN			
Output type	PNP	/	PNP	PNP	/			
Sensor supply current	2 A	500 mA	/	500 mA	500 mA			
Actuator output current	2 A	/	2 A	2 A	/			
ASDM								
Sensor load open circuit detection	Approved		/	Approved				
Sensor load short-circuit detection	Approved		/	Approved				
Actuator output point fault diagnosis	Approved	/	Approved	Approved		/		







CONFIGURATION PRODUCT





7/8" Port connection DeviceNet

		7/8" 5pin	7/8" 5pin	7/8" 5pin	7/8" 5pin	7/8" 5pin
DNU ①						
2 x 23AWG + 2 x 22AWG	Fixed	978131-807-XXXX	978121-807-XXXX	950121-807-XXXX	978081	978201
	Flex	978131-803-XXXX	978121-803-XXXX	950121-803-XXXX		



		7/8" 5pin	7/8" 5pin	7/8" 5pin	7/8" 5pin	7/8" 5pin
DNU ①						
2 x 23AWG + 2 x 22AWG	Fixed	978181-807-XXXX	978151-807-XXXX	950151-807-XXXX	978141	978261
	Flex	978181-803-XXXX	978151-803-XXXX	950151-803-XXXX		

7/8" Port connection DeviceNet

		7/8" 4pin	7/8" 4pin	7/8" 4pin	7/8" 4pin	7/8" 4pin
DNU ②						
4x1.5mm ²	Fixed	978011-964-XXXX	978041-964-XXXX	950020-964-XXXX	978101	978221
	Flex	978011-960-XXXX	978041-960-XXXX	950020-960-XXXX		

		7/8" 4pin	7/8" 4pin	7/8" 4pin	7/8" 4pin	7/8" 4pin
DNU ②						
4x1.5mm ²	Fixed	978071-964-XXXX	978061-964-XXXX	950050-964-XXXX	978142	978262
	Flex	978071-960-XXXX	978061-960-XXXX	950050-960-XXXX		

Terminal

	7/8" Terminal	7/8" Male protection cover Label plates (metal)	7/8" Female protection cover (metal)
			
Suppression Part No.	Devicenet 5-pin 978301	955491	955691

IO lines and accessories are on pages A1.6.7-A1.6.10

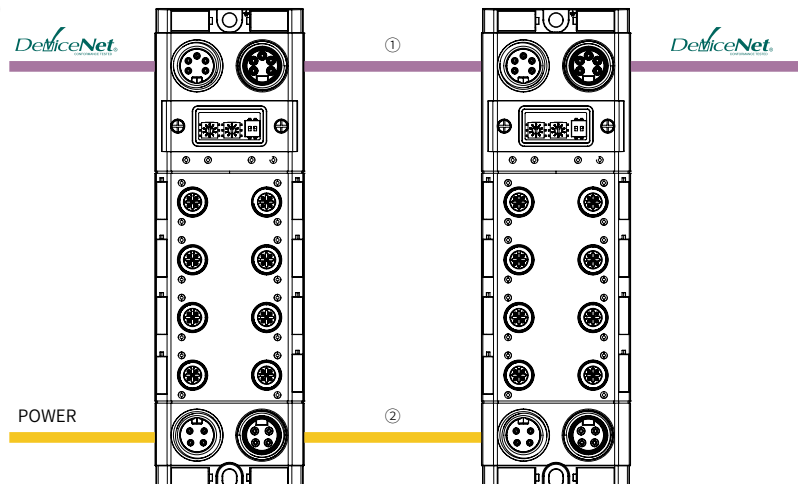

CONFIGURATION PRODUCT

7/8" Eth port connection Profinet/EtherCAT/EtherNetIP/CC-link Field Basic/Modbus

		M12 4pin D-code	M12 4pin D-code	M12 to RJ45 4pin	Connector Shielded 4pin fielded-wireable (Wire gauge) Part No.:
NETU ①					914521 (22-26AWG)
Profinet (2x2x22AWG)	Fixed	914541-790-XXXX	944511-790-XXXX	944711-790-XXXX	999051 (22-24AWG) 999181 (24-26AWG)
	Flex	914541-796-XXXX	944511-796-XXXX	944711-796-XXXX	
CAT 5e. (2x2x24AWG)	Fixed	914541-795-XXXX	944511-795-XXXX	944711-795-XXXX	
	Flex	914541-797-XXXX	944511-797-XXXX	944711-797-XXXX	
CAT 5e. (2x2x26AWG)	Fixed	914541-791-XXXX	944511-791-XXXX	944711-791-XXXX	999061 (22-24AWG) 999071 (24-26AWG)
	Flex	914541-793-XXXX	944511-793-XXXX	944711-793-XXXX	

		M12 4pin D-code	M12 4pin D-code	M12 to RJ45 4pin	Connector Shielded 4pin fielded-wireable (Wire gauge) Part No.:
NETU ①					914581
Profinet (2x2x24AWG)	Fixed	914561-790-XXXX	944561-790-XXXX	944761-790-XXXX	M12 Female blind plug
	Flex	914561-796-XXXX	944561-796-XXXX	944761-796-XXXX	
CAT 5e. (2x2x24AWG)	Fixed	914561-795-XXXX	944561-795-XXXX	944761-795-XXXX	996050
	Flex	914561-797-XXXX	944561-797-XXXX	944761-797-XXXX	
CAT 5e. (2x2x26AWG)	Fixed	914561-791-XXXX	944561-791-XXXX	944761-791-XXXX	
	Flex	914561-793-XXXX	944561-793-XXXX	944761-793-XXXX	

7/8" power connection

		7/8" 5pin	7/8" 5pin	7/8" 5pin	7/8" 5pin	7/8" 5pin
NETU ②						
5x1.5mm ²	Fixed	978031-961-XXXX	978021-961-XXXX	950021-961-XXXX	978081	978201
	Flex	978031-962-XXXX	978021-962-XXXX	950021-962-XXXX		

		7/8" 5pin	7/8" 5pin	7/8" 5pin	7/8" 5pin	7/8" 5pin
NETU ②						
5x1.5mm ²	Fixed	978091-961-XXXX	978031-961-XXXX	950051-961-XXXX	978141	978261
	Flex	978091-962-XXXX	978031-962-XXXX	950051-962-XXXX		

IO lines and accessories are on pages A1.6.7-A1.6.10

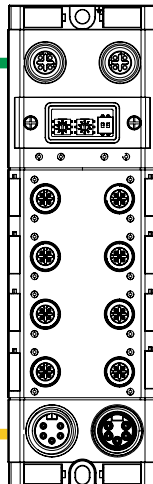

①

②







POWER

FIELD BUS REMOTE I/O MODULE

Advanced diagnostic function
Industrial grade plastic module
Digital





Protocol	Signal type	16 DI	16 DO	8 DI + 8 DO
	Type	DPL16DI	DPL16DO	DPL16DM
	Part No.	104105019	202105019	305105019
	Type	DNL16DI	DNL16DO	DNL16DM
	Part No.	104105017	202105017	305105017
	Type	CKL16DI	CKL16DO	CKL16DM
	Part No.	104105012	202105012	305105012
	Type	CPL16DI	CPL16DO	CPL16DM
	Part No.	104105013	202105013	305105013

Technical data	
Rated working voltage U_B	18...30 V DC
Function indicator LED	SF/BF/RDY
Port status indicator	Red, Green
Power LED	U_A (Red, Green) U_S (Red, Green)
Network port	M12, A-code, 5 pin (Profibus: M12, B-code, 5 pin)
Power interface	M12, T-Code, 4 pin, max. 12A
Housing Material	PA
Degree protection	IP67
I/O port	
Connection	M12, A code, Female
I/O Number of I/O ports	8
Input	PNP
Output	PNP
Sensor supply current	500 mA
Actuator output current	500 mA

REMOTE I/O MODULE

Basic diagnosis
Industrial plastic module
Digital



Protocol	Signal type	16 DI	16 DO	8 DI + 8 DO	16 DI/16 DO
	Type	PNL16DI	PNL16DO	PNL16DM	PNL16DP
	Part No.	104105015	202105015	305105015	302102015
	Type	ECL16DI	ECL16DO	ECL16DM	ECL16DP
	Part No.	104105018	202105018	305105018	302102018

Technical data	
Rated working voltage U_B	18...30 V DC
Function indicator LED	SF/BF/RDY
Port status indicator	Green
Power LED	U_A (Red, Green) U_S (Red, Green)
Network port	M12, D-code, Female
Power interface	M12, T-Code, 4 pin, max. 12A
Max current	Max. 12A
Housing Material	PA
Degree protection	IP67
I/O port	
Connection	M12, A code, Female
I/O Number of I/O ports	8
Input	PNP
Output	PNP
Sensor supply current	500 mA
Actuator output current	500 mA



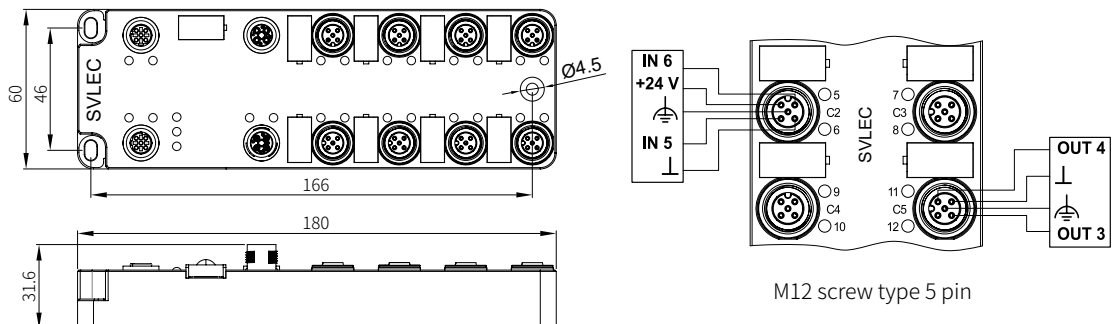

■ Drawing

Unit : mm



CONFIGURATION PRODUCT

■ Profibus Plastic module communication interface

		M12 2pin D-code	M12 2pin D-code	M12 2pin D-code	M12 5-pin B-Code	M12 5-pin B-Code
DPL						
1x2xØ0.64mm	Fixed	914051-840-XXXX	914061-840-XXXX	944001-840-XXXX	914001	914021
	Flex	914051-841-XXXX	914061-841-XXXX	944001-841-XXXX		





		M12 2pin D-code	M12 2pin D-code	M12 2pin D-code	M12 5-pin B-Code	M12 5-pin B-Code
DPL						
1x2xØ0.64mm	Fixed	914081-840-XXXX	914071-840-XXXX	944021-840-XXXX	914011	914031
	Flex	914081-841-XXXX	914071-841-XXXX	944021-841-XXXX		





■ Profibus Plastic module power interface

		M12 4pin T-code	M12 4pin T-code	M12 4pin T-code	M12 4pin T-code	M12 Y 4pin
PNM/ECM/EPM/CEM/FBM/OPM						
4x1.5mm ²	Fixed	912044-964-XXXX	912344-964-XXXX	942044-964-XXXX	912932	942121
	Flex	912044-960-XXXX	912344-960-XXXX	942044-960-XXXX		

		M12 4pin T-code	M12 4pin T-code	M12 4pin T-code	M12 T 4pin T-code	M12 Terminal Profibus
PNM/ECM/EPM/CEM/FBM/OPM						
4x1.5mm ²	Fixed	912045-964-XXXX	912345-964-XXXX	942073-964-XXXX	943061	B-Code 5 pin 914041
	Flex	912045-960-XXXX	912345-960-XXXX	942073-960-XXXX		

■ DeviceNet/CC-LINK/CANopen Plastic module communication interface

		M12 5pin A-code	M12 5pin A-code	M12 5pin A-code	M12 5-pin A-Code	M12 5-pin A-Code
DNL/CKL/CPL						
2 x 23AWG + 2 x 22AWG	Fixed	913105-807-XXXX	913225-807-XXXX	940531-807-XXXX	913321	913401
	Flex	913105-803-XXXX	913225-803-XXXX	940531-803-XXXX		

		M12 5pin A-code	M12 5pin A-code	M12 5pin A-code	M12 5-pin A-Code	M12 5-pin A-Code
DNL/CKL/CPL						
2 x 23AWG + 2 x 22AWG	Fixed	913125-807-XXXX	913251-807-XXXX	940551-807-XXXX	913361	913441
	Flex	913125-803-XXXX	913251-803-XXXX	940551-803-XXXX		

■ DeviceNet/CC-LINK/CANopen Plastic module power interface







		M12 4pin T-code	M12 4pin T-code	M12 4pin T-code	M12 4pin T-code	M12 Y 4pin
DNL/CKL/CPL						
4x1.5mm ²	Fixed	912044-964-XXXX	912344-964-XXXX	942044-964-XXXX	912932	942121
	Flex	912044-960-XXXX	912344-960-XXXX	942044-960-XXXX		







CONFIGURATION PRODUCT

■ DeviceNet/CC-LINK/CANopen Plastic module power interface

		M12 4pin T-code	M12 4pin T-code	M12 4pin T-code	M12 T 4pin T-code
DNL/CKL/CPL					
4x1.5mm ²	Fixed	912045-964-XXXX	912345-964-XXXX	942073-964-XXXX	943061
	Flex	912045-960-XXXX	912345-960-XXXX	942073-960-XXXX	

■ Plastic module Ethernet communication interface Profinet & EtherCAT

		M12 4pin D-code	M12 4pin D-code	M12 to RJ45 4pin	Connector Shielded 4pin fielded-wireable (Wire gauge) Part No.:
PNL/ECL					 914521 (22-26AWG)
Profinet (2x2x24AWG)	Fixed	914541-790-XXXX	944511-790-XXXX	944711-790-XXXX	 999051 (22-24AWG) 999181 (24-26AWG)
	Flex	914541-796-XXXX	944511-796-XXXX	944711-796-XXXX	
CAT 5e. (2x2x24AWG)	Fixed	914541-795-XXXX	944511-795-XXXX	944711-795-XXXX	 999061 (22-24AWG) 999071 (24-26AWG)
	Flex	914541-797-XXXX	944511-797-XXXX	944711-797-XXXX	
CAT 5e. (2x2x26AWG)	Fixed	914541-791-XXXX	944511-791-XXXX	944711-791-XXXX	 999061 (22-24AWG) 999071 (24-26AWG)
	Flex	914541-793-XXXX	944511-793-XXXX	944711-793-XXXX	

		M12 4pin D-code	M12 4pin D-code	M12 to RJ45 4pin	Connector Shielded 4pin fielded-wireable (Wire gauge) Part No.:
PNL/ECL					 914581
Profinet (2x2x22AWG)	Fixed	914561-790-XXXX	944561-790-XXXX	944761-790-XXXX	M12 female screw plug
	Flex	914561-796-XXXX	944561-796-XXXX	944761-796-XXXX	
CAT 5e. (2x2x24AWG)	Fixed	914561-795-XXXX	944561-795-XXXX	944761-795-XXXX	 996050
	Flex	914561-797-XXXX	944561-797-XXXX	944761-797-XXXX	
CAT 5e. (2x2x26AWG)	Fixed	914561-791-XXXX	944561-791-XXXX	944761-791-XXXX	 996050
	Flex	914561-793-XXXX	944561-793-XXXX	944761-793-XXXX	

■ Plastic module power interface Profinet & EtherCAT

		M12 4pin T-code	M12 4pin T-code	M12 4pin T-code	M12 4pin T-code	
PNL/ECL						
4x1.5mm ²	Fixed	912044-964-XXXX	912344-964-XXXX	942044-964-XXXX	912744	912932
	Flex	912044-960-XXXX	912344-960-XXXX	942044-960-XXXX		

		M12 4pin T-code	M12 4pin T-code	M12 4pin T-code	M12 T 4pin T-code
PNL/ECL					
4x1.5mm ²	Fixed	912045-964-XXXX	912345-964-XXXX	942073-964-XXXX	943061
	Flex	912045-960-XXXX	912345-960-XXXX	942073-960-XXXX	



IO lines and accessories are on pages A1.6.7-A1.6.10

SV-Link™ Module



Standardized installation

Flexible response to enduser needs

You only need to configure the machine once

You only need to create the document once

Use only one system operation technique to

Minimize inventory



More information please visit
www.svlcc.com

1 master module can connect 32 slave modules

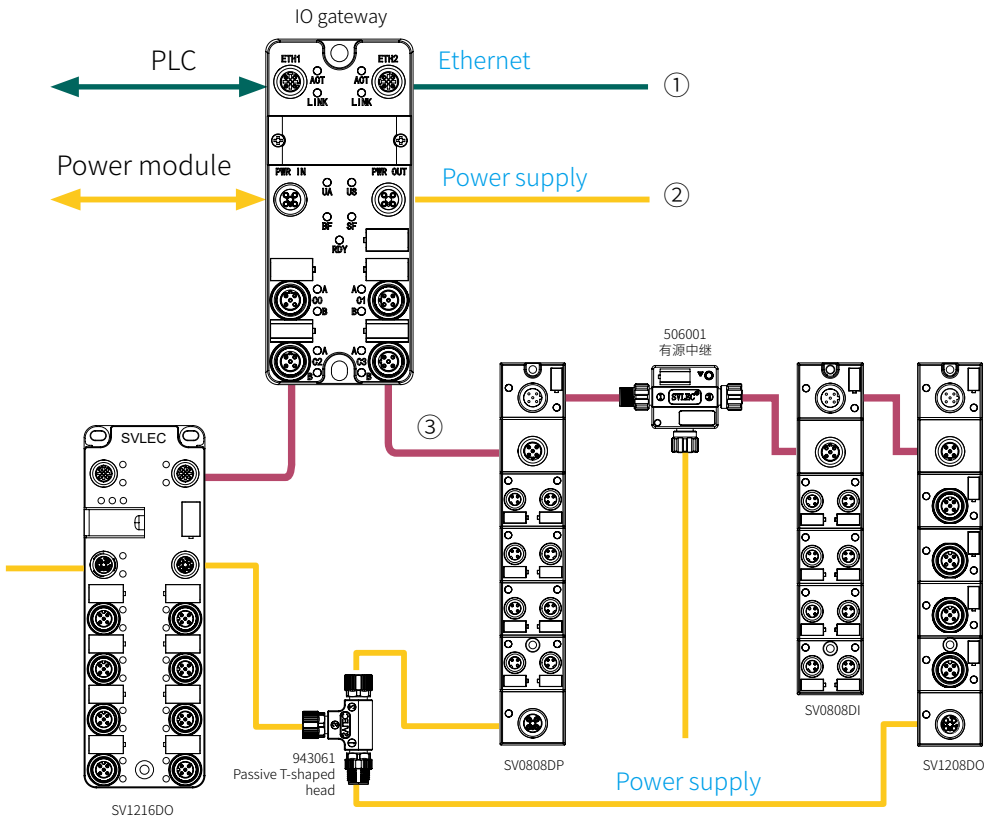

- ◆ 4 Route
- ◆ Every road support:
 - 8 Modules
 - 30 meters of cable
- ◆ Diagnose each I/O stitch
- ◆ Display the status of each pin
- ◆ Topology
 - Star / Line
- ◆ Transport type
 - Depending on the situation
- ◆ System connection
 - M12 Hybrid cable
- ◆ Address
 - Automatic access to

The gateway and extension modules can be flexibly configured to provide continuous diagnosis

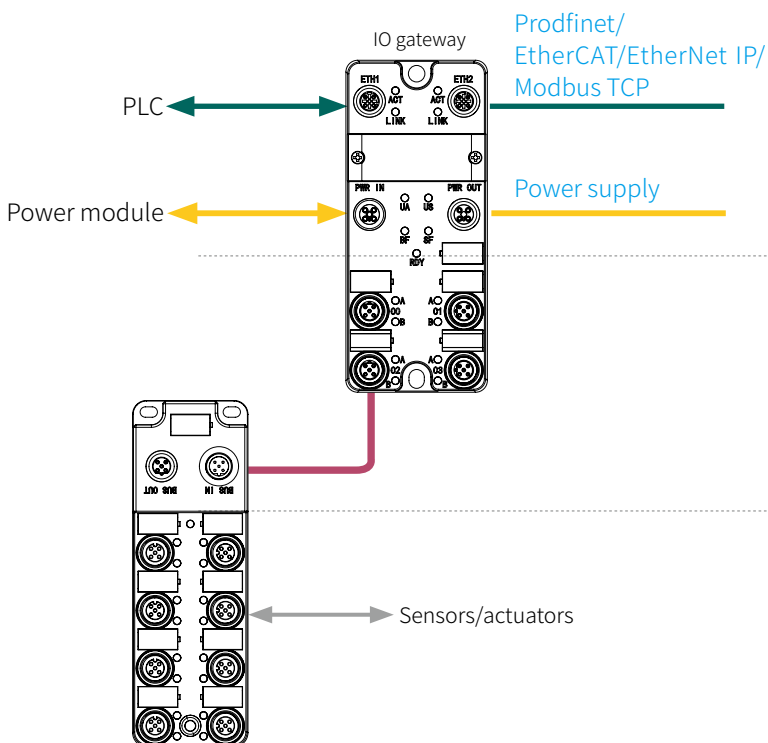

Bus node

- ◆ Communication
- ◆ Module
- ◆ Undervoltage diagnosis
- ◆ Overload diagnosis





I/O Module

- ◆ Communication
- ◆ Undervoltage diagnosis
- ◆ Overload diagnosis

Port

- ◆ Signal state diagnosis
- ◆ Diagnosis of abnormal values
- ◆ Short-circuit diagnosis
- ◆ Overload diagnosis
- ◆ Cable break diagnosis
- ◆ Actuator alarm



					
Type	PN4M	EC4M	EP4M	OP4M	FB4M
Part No.	509105015	509105018	509105016	509105012	509105013
Technical data					
Net connections	Ethernet 10 / 100 Mbit/s; M12, D-code				
Service connection impedance	M12 T-code, max. 12A				
SV-Link Output	M12 B-code Female, 5 pins, max. 4A				
Nominal voltage	24 V DC (EN 61131-2)				
Current loss	max. 200 mA				
Address	DHCP, BOOTP				
SV-Link system					
Module capacity	max. 32				
I/O capacity	max. 250 Bytes				
Port number	4				
LED indicating	Communication and power supply				
Monitor - Low voltage	Yes				
Detection - No voltage	Yes				
Short circuit and overload	Yes				
Specifications					
Degree protection	IP67				
Installation	2- fix with screw				
Temperature range	-25...+60 ° C				

■ Drawing

Unit : mm

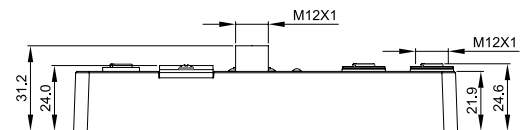
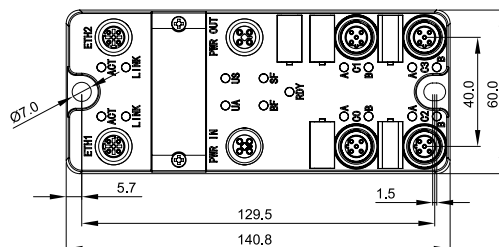

SV-Link™ EXTENSION MODULE

The extended distance Max 30 m



OBOM	16DI	16DO
Type	SV1216DI	SV1216DO
Part No.	509106	509108
Technical data		
Net connection	SV-Link, M12 B-code, 5 pins	
Power supply	SV-Link, max. 4A	
Rated voltage	18...30 V DC	
Current loss	30 mA	
I/O port		
Power supply mode	Pass SV-Link	System pass SV-Link, output PassM12 T-code, 4pins
I/O connection	M12 Female 5 pins, A-code	
Input quantity	16 ↑ PNP	/
Output qty	/	16 ↑ PNP
Output current	Port max. 500 mA	Per channel max. 500 mA
LED indicating	Input signal and power supply	Output signal and power supply
Monitor - Low voltage	Yes	
Detection - No voltage	Yes	
Short circuit and overload	Yes	
Specifications		
Degree of protection	IP67	
Installation	2-fix with screw	
Temperature range	-25...+60 ° C	

■ Drawing

Unit : mm

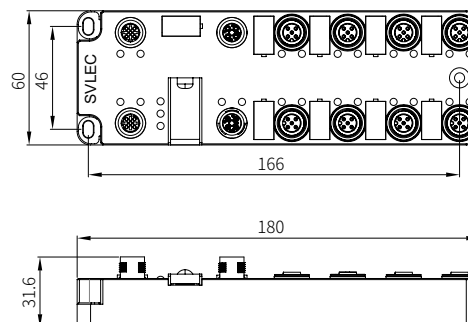
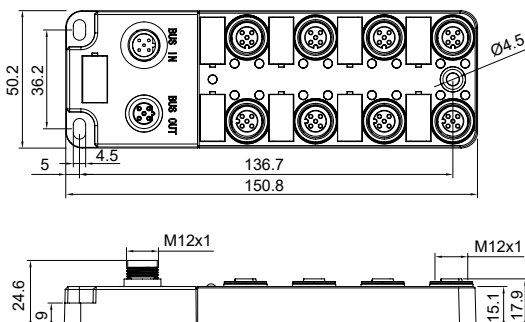

M8 Narrow series

Digital input / output



Assisted safety valve power interface

T-Code
SV0808DP

Type	SV0808DI	SV0808DP	SV0808DPN
Part No.	509126	509127	509227
Form	8DI PNP / NPN	8DI/DO PNP	8DI/DO NPN
Technical data			
Auxiliary power supply system	No	Yes	
Current loss	max. 30 mA		
LED indicating	US: Sensor and internal power supply voltage (Green: normal); UA: Actuator power supply (Green: normal)		
Net connection	Connect through internal systems		
I/O port	M8 (Female) 3 pins, A-code		
Input Sensor power supply US	24 V DC (EN 61131-2), Max 200 mA per M8 Female, (Shortcircuit overload protection)		
Input filter	1 ms		
Max current load, Sensor	500 mA	500 mA	
Max current load, Actuator	/	500 mA	
Traffic Status	By LED		
LED Indicator	Per module and channel		
Diagnostics via bus	Per module and channel		
Monitor - Low voltage	Yes		
Detect -No voltage	Yes		
Short circuit and overload	Yes		
Specifications			
Degree of protection	IP67		
Installation	2- 孔 fix with screw		
Temperature range	-25...+60 °C		

■ Drawing

Unit : mm

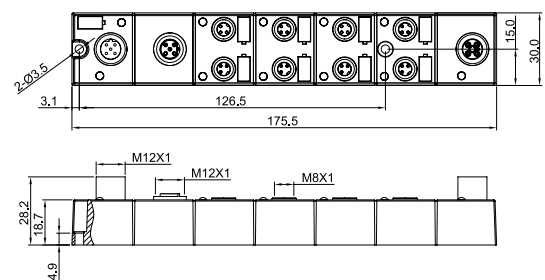
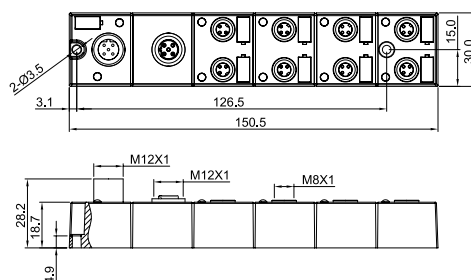

SV-Link™ EXTENSION MODULE

M12 Narrow series

Digital input / output



Assisted safety valve
power interface

T-Code
SV1208DO

Type	SV1208DI	SV1208DM	SV1208DMN	SV1208DO
Part No.	509116	509115	509215	509118
Type	8DI PNP / NPN	4DI+4DO PNP	4DI+4DO NPN	8DO PNP
Technical data				
Auxiliary power supply system	No	Yes		
Current loss	max. 50 mA			
LED indicating	US: Sensor and internal power supply voltage (Green: normal); UA: Actuator power supply (Green: normal)			
Net connection	Connect through internal systems			
I/O port	M12 (Female) 5 pin, A-code			
US input	24 V DC (EN 61131-2), Max 200 mA per M8 Female, (Shortcircuit and overload protection)			
Input filter	1 ms			
Max load current : Sensor	500 mA			
Max load current : Actuator	/	500 mA		/
Traffic Status	Pass LED	500 mA		2A
LED Indicator	Per module and channel			
Diagnostics via bus	Per module and channel			
Monitor - Low voltage	Yes			
Detect -No voltage	Yes			
Short circuit and overload	Yes			
Specifications				
Degree of protection	IP67			
Installation	2-fix with screw			
Temperature range	-25...+60 °C			

■ Drawing

Unit: mm

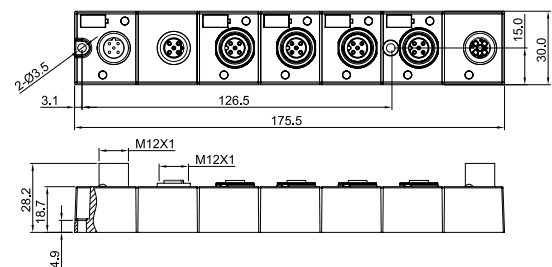
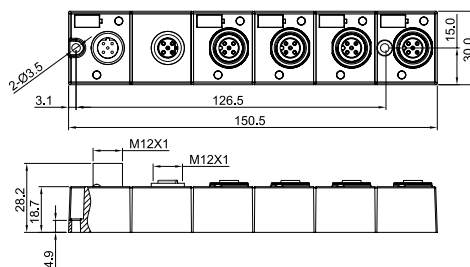

M12 narrow series

Analog



SV1201AI



Type	SV1204AI	SV1204AO	SV1204AT	SV1201AI
Part No.	509113	509112	509111	509110
Form	4* Analog Input	4 *Analog output	4 *temp.	1 * Analog Input
Technical data				
Auxiliary power supply system	No			
Current loss	max. 50 mA			
indicating LED	US: Sensor and internal power supply voltage (Green: normal)			
Fieldbus	Connect through internal systems			
Power: US/ U A	Connect through internal systems (max. 2×4 A)			
I/O port	M12 (Female) 5 pins, A-code			
I/O port Number	4			
Sensor	/			
Input range	Vol mode: ±10V DC,0-10V DC; Current: 0-20mA, 4-20mA	/	PT100,PT100 Thermocouple	Input range: Voltage: ±10V DC,0-10V DC; Current: 0-20mA,4-20mA Temp: PT100,PT1000,Thermocouple
Output range	/	Vol ±10V DC,0-10V DC; Current 0-20mA, 4-20mA	/	/
Voltage mode input resistor	About 1MΩ, differential input	/	/	About 1MΩ, differential input
Load	Current: About 300 Ω,differential input	Vol: min. 500 Ω; Current: max. 500 Ω	/	Current: 300 Ω,differential input
Resolution	15 + sign bit			
Precision	±0.5%			
Specifications				
Degree of protection	IP67			
Installation	2-fix with screw			
Temperature range	-25...+60 ° C			





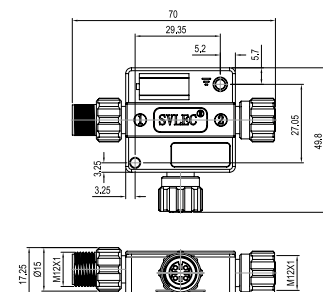
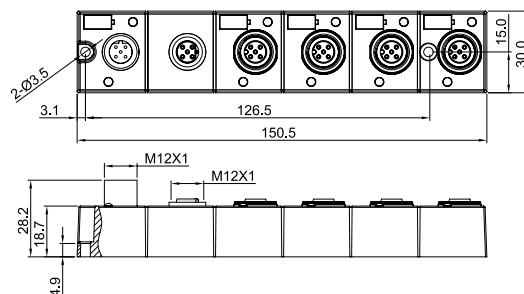

■ Drawing





Unit : mm



CONFIGURATION PRODUCT

SV-LINK Ethernet communication interface of main station module

		M12 4pin D-code	M12 4pin D-code	M12 RJ45 4pin	Connector Shielded 4pin fielded-wireable (Wire gauge) Part No.:	
PN4M/EC4M/EP4M/FB4M/OP4M ①						914521 (22-26AWG)
Profinet (2x2x22AWG)	Fixed	914541-790-XXXX	944511-790-XXXX	944711-790-XXXX		999051 (22-24AWG) 999181 (24-26AWG)
	Flex	914541-796-XXXX	944511-796-XXXX	944711-796-XXXX		
CAT 5e. (2x2x24AWG)	Fixed	914541-795-XXXX	944511-795-XXXX	944711-795-XXXX		999061 (22-24AWG) 999071 (24-26AWG)
	Flex	914541-797-XXXX	944511-797-XXXX	944711-797-XXXX		
CAT 5e. (2x2x26AWG)	Fixed	914541-791-XXXX	944511-791-XXXX	944711-791-XXXX		999061 (22-24AWG) 999071 (24-26AWG)
	Flex	914541-793-XXXX	944511-793-XXXX	944711-793-XXXX		



		M12 4pin D-code	M12 4pin D-code	M12 RJ45 4pin	Connector Shielded 4pin fielded-wireable (Wire gauge) Part No.:	
PN4M/EC4M/EP4M/FB4M/OP4M ①						
Profinet (2x2x22AWG)	Fixed	914561-790-XXXX	944561-790-XXXX	944761-790-XXXX	914581	
	Flex	914561-796-XXXX	944561-796-XXXX	944761-796-XXXX		
CAT 5e. (2x2x24AWG)	Fixed	914561-795-XXXX	944561-795-XXXX	944761-795-XXXX		
	Flex	914561-797-XXXX	944561-797-XXXX	944761-797-XXXX		
CAT 5e. (2x2x26AWG)	Fixed	914561-791-XXXX	944561-791-XXXX	944761-791-XXXX		
	Flex	914561-793-XXXX	944561-793-XXXX	944761-793-XXXX		

SV-LINK Main station power interface

		M12 4pin T-code	M12 4pin T-code	M12 4pin T-code	M12 4pin T-code	从站回路电源中继器
PN4M/EC4M/EP4M/FB4M/OP4M ②						
1.5mm ²	Fixed	912044-964-XXXX	912344-964-XXXX	942044-964-XXXX	912744	506001
	Flex	912044-960-XXXX	912344-960-XXXX	942044-960-XXXX		

		M12 4pin T-code	M12 4pin T-code	M12 4pin T-code	M12 T 4pin T-code	
PN4M/EC4M/EP4M/FB4M/OP4M ②						
1.5mm ²	Fixed	912045-964-XXXX	912345-964-XXXX	942073-964-XXXX	912932	
	Flex	912045-960-XXXX	912345-960-XXXX	942073-960-XXXX		

SV-LINK Master slave station&slave to slave module Ethernet communication interface





		M12 5pin B-code	M12 5pin B-code	M12 5pin B-code	M12 5pin B-code	辅助电源接口串联
SV08 & SV12 ③						
0.34mm ²	Fixed	940501B-817-XXXX	944132B-817-XXXX	914001	914021	943061
	Flex	940532-803-XXXX	940550-803-XXXX			

IO lines and accessories are on pages A1.6.7-A1.6.10

IP20 REMOTE I/O MODULE

Basic diagnosis



Ordering information		16DI+16DO (Transistor)	32DI	16DI+16DO (Relay)
	Type	PNK32DM	PNK32DI	PNK32DR
	Part No.	207105015	207106015	207107015
	Type	ECK32DM	ECK32DI	ECK32DR
	Part No.	207105018	207106018	207107018
	Type	EPT32DM	EPT32DI	EPT32DR
	Part No.	205105016	205106016	205107016
	Type	FBT32DM	FBT32DI	FBT32DR
	Part No.	205105013	205106013	204107013
Technical data				
Rated working voltage U_b		18...30 V DC		
Function indicator LED		SF/BF/RDY		
I/O status LED		Red, Green		
Network port		RJ45, Female		
Power interface		Spring type terminal		
Degree protection		IP20		
I/O port				
I/O Connection		Spring type terminal		
I/O Number of I/O ports		32		
Input	16 * PNP / NPN	32*PNP/NPN	16*PNP/NPN	
Output	16 PNP output(Transistor)/500 mA	/	16 normally open contacts / 1A	



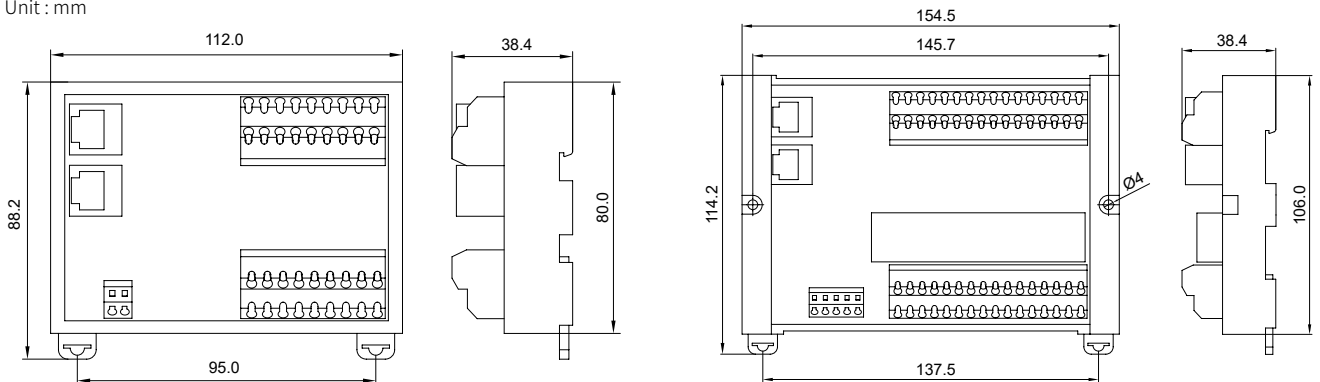

■ Drawing

Unit : mm



IP20 MASTER STATION



Ordering information		16DI + 4 IO-LINK master + SV-LINK	16DI+16DO+SV-LINK	32DI + SV-LINK
	Type	PNQ16IK	PNQ32DM	PNQ32DI
	Part No.	206104015	206105015	206106015
	Type	ECQ16IK	ECQ32DM	ECQ32DI
	Part No.	206104018	206105018	206106018
	Type	EPQ16IK	EPQ32DM	EPQ32DI
	Part No.	206104016	206105016	206106016
	Type	FBQ16IK	FBQ32DM	FBQ32DI
	Part No.	206104013	206105013	206106013
Technical data				
Rated working voltage U_B		18...30 V DC		
Function indicator LED		RDY,BF,SF,SYN		
I/O status LED		Red, Green		
Network port		RJ45, Female		
Power interface		Spring type terminal		
Degree protection		IP20		
I/O port				
I/O Connection		Spring type terminal		
I/O Number		32		
With SV-LINK extension port		Yes		
Input		PNP / NPN		
Output		PNP		
Actuator output current		500 mA		

Note: 4 I/O-link ports Scalable with 4xIO-Link slave station, SV-Linkport Scalable with 6xIP67 slave station .

■ Drawing

Unit : mm

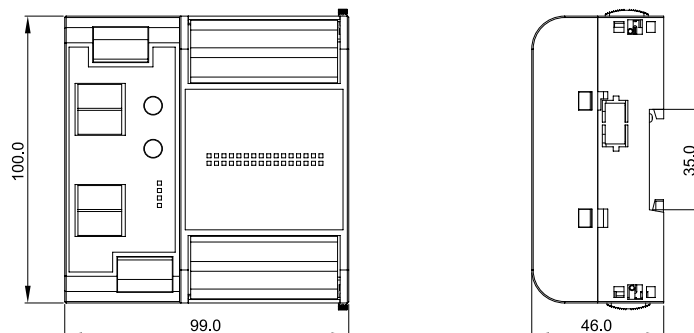

IP20 SV-Link™ EXTENDED MODULE

Scalable 6



Ordering information	32DI	32DO	16DI + 16DO	8AI	8AO	8AT
Type	SVQ32DI	SVQ32DO	SVQ32DM	SVQ08AI	SVQ08AO	SVQ08AT
Part No.	508106	508108	508107	508105	508104	508103
Technical data						
Rated working voltage U_b	18...30 V DC					
Function indicator LED	IO/SV-LINK					
I/O status LED	Red, Green					
Power interface	Spring type terminal					
Degree protection	IP20					
I/O port						
I/O Connection	Spring type terminal					
I/O Number	32			8		
With SV-LINK extension port	Yes			Yes		
Input	PNP / NPN			Current and voltage /		PT100、PT1000 Thermocouple
Output	PNP			/		Current and voltage /
Actuator output current	500 mA			/		

■ Drawing

Unit : mm

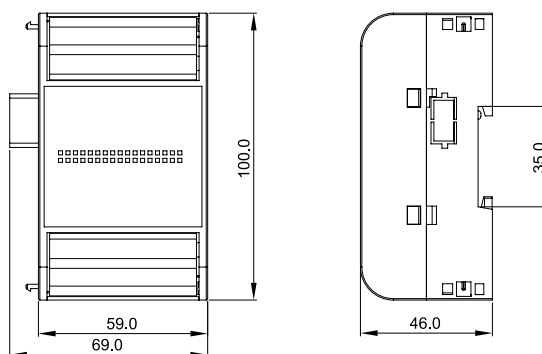

IP20 DISTRIBUTED I/O SYSTEM

The SVLEC S1 series distributed IO system adopts a multi-protocol design method and is suitable for common bus networks, the compact design as thin as 12mm, and 100 M communication, which can make the module achieve microsecond response speed. The S1 series distributed module is a good choice for automation solutions. Extremely easy to install, with excellent continuous operation and high responsiveness.



Type	S1-M20	S1-EC20	S1-PN20	S1-FB20	S1-OP20	S1-IOL20
Part No.	701102001	701102003	701102004	701102005	701102006	701102002
Protocol						
Technical data						
Rated working voltage U_B	18...30 V DC					18...30 V DC
Function indicator LED	SYS,US,BF,SF,RDY					SYS,US,SF
Network port	RJ45, Female					Spring type terminal
Power interface	Spring type terminal					Spring type terminal
Degree protection	IP20					IP20
I/O Connection	backboard extension					backboard extension
Remote expansion	64 (EtherCAT:32)	64				16
Input out put process Byte	according to protocol	1024/1024		256/256	1024/1024	32/32
Backboard working voltage	5V					
Protocol switch	DIP switch	/				

Note: S1-IOL20 can not connect with S1-04IOL、SI-04MD、S1-01MD

S1-IOL20 is IO-LINK coupler, Can connect below IO-LINK master, and expanded with DI/DO/analyse module,max32 byte

S1-M20+S1-04IOL Assembled as 4 port IO-link master

S1-M20+S1-04MD Assembled as RFID gateway, can connect with SV-LINK Pro

S1-M20+S1-01MD Assembled as 1 way common RS485/RS232 gateway

■ Drawing

Unit : mm

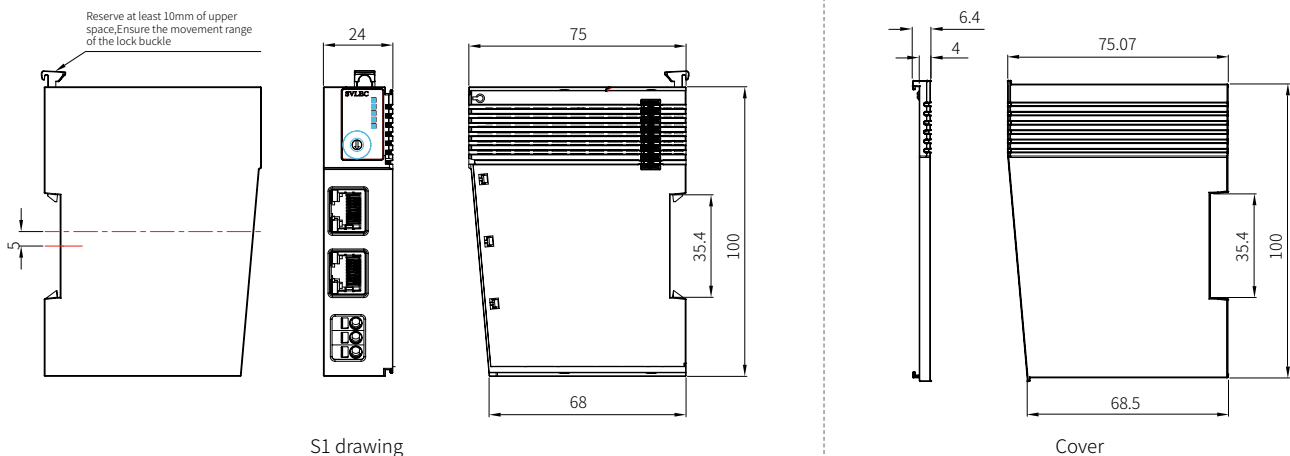

S1 drawing

Cover

IP20 EXTENDED MODULE

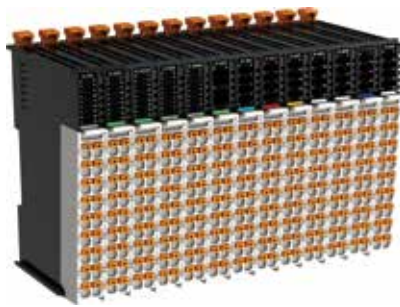

Width 12mm



Width 24mm

Type	Part No.	Signal type	Channel	Signal polarity	Width
S1-16DI	506101	Digital input	16	PNP / NPN	12mm
S1-16DO	506102	Digital output 0.5A	16	PNP	12mm
S1-16DON	506103	Digital output 0.5A	16	NPN	12mm
S1-16DM	506104	Digital input + Digital output 0.5A	8+8	PNP + PNP	12mm
S1-16DMN	506105	Digital input + Digital output 0.5A	8+8	NPN + NPN	12mm
S1-32DI	506106	Digital input	32	PNP / NPN	24mm
S1-32DO	506107	Digital output 0.5A	32	PNP	24mm
S1-32DON	506108	Digital output 0.5A	32	NPN	24mm
S1-32DM	506109	Digital input + Digital output 0.5A	16+16	PNP / NPN + PNP	24mm
S1-32DMN	506110	Digital input + Digital output 0.5A	16+16	PNP / NPN + NPN	24mm
S1-04DR	506111	Relay 5A output	4		12mm
S1-08AI	506112	Analog input、Current $\pm 20\text{mA}$ 、Voltage $\pm 10\text{V}$	8	/	12mm
S1-08AO	506113	Analog output、Current $\pm 20\text{mA}$ 、Voltage $\pm 10\text{V}$	8	/	12mm
S1-04AT	506114	Temp input (RTD/ TC) Temperature input	4	/	12mm
S1-04IOL	506115	IO-LINK Master station port	4	/	12mm
S1-04MD	506116	RFID gateway can connect with SV-LINK Pro	4	/	12mm
S1-04PM	506117	PWM output	4	/	12mm
S1-04JS	506118	High speed counter	4	/	12mm
S1-01PR	506119	Power relay module	1	/	12mm
S1-01MD	506120	Communication module (485/232/422)	1	/	12mm

Note: Each 8 expand module need to add a power relay S1-01PR

■ Drawing

Unit : mm

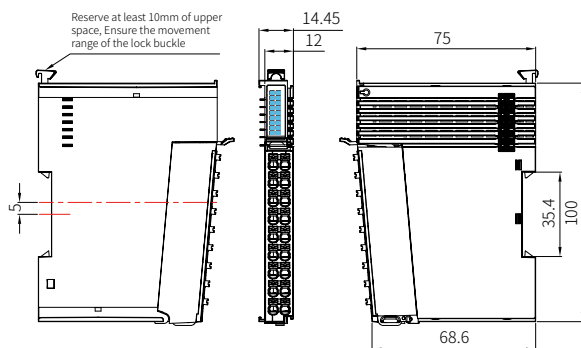



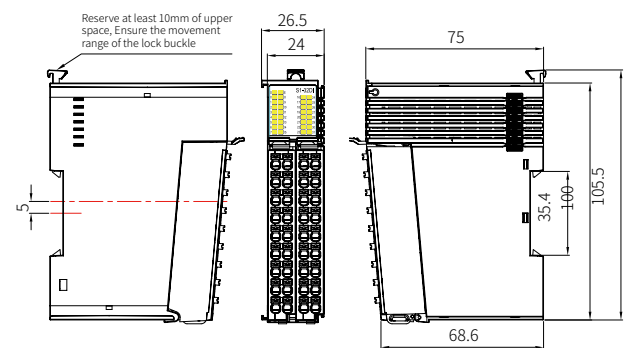







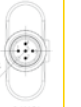

Width 12mm











Width 24mm

Y CONNECTION

	Y-shaped fixed bracket	M12-2M8 Y type	M12-2M12 Y type			7/8" T type			M12-2 7/8" T type
									
Pole		5-pole	4-pole	5-pole	5-pole	3-pole	4-pole	5-pole	5-pole
Part No.	63014204	941201	941131	941121	942121	950031	950071	950061	950081

	M12 dual hole connector	M12-2M12 T type DeviceNet	M12-2M12 Y type Profibus	M12 - M12 T type T-code	M12 - M12 T type L-code
					
Pole	2-pole	5-pole	B-Code 5-pole	4-pole	5-pole
Part No.	912700	941061	940061	943061	943062

		M12-2T		Y type M12 - M12		Y type M12 - M8		Y type M12 - M12	
									
Pole		3-pole	4-pole	3-pole	4-pole	3-pole	3-pole	3-pole	4-pole
black	Fixed	940941-613-XXXX	940901-614-XXXX	940701-613-XXXX	940721-614-XXXX	940821-610-XXXX		940752-614-XXXX	940753-614-XXXX
black	Flex	940941-633-XXXX	940901-634-XXXX	940701-633-XXXX	940721-634-XXXX	940821-630-XXXX		940752-634-XXXX	940753-634-XXXX
orange	Anti-weld slag		940901-054-XXXX		940721-054-XXXX	940821-050-XXXX		940752-054-XXXX	940753-054-XXXX

Circuit diagram

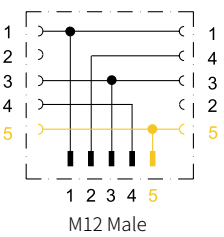
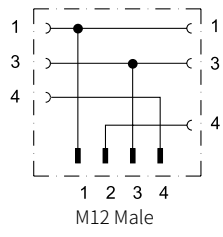
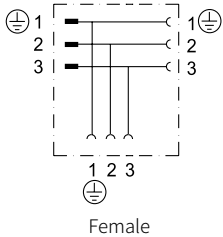
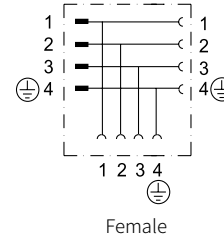
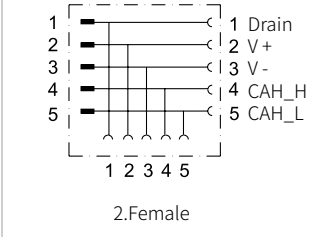
<p>1.Female M12 2.Female</p>  <p>① 5-core circuit diagram</p>	<p>1.Female M8 2.Female</p>  <p>② 4-core circuit diagram</p>	<p>Male Female</p>  <p>③ 3-core circuit diagram</p>	<p>Male Female</p>  <p>④ 4-core circuit diagram</p>	<p>Male 1.Female</p>  <p>⑤ 5-core circuit diagram</p>
--	---	--	---	--

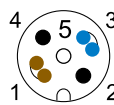
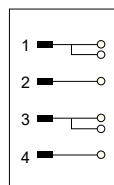

Note: The pin 1 and pin3 can simultaneously meet the requirement of connecting two power wires each.



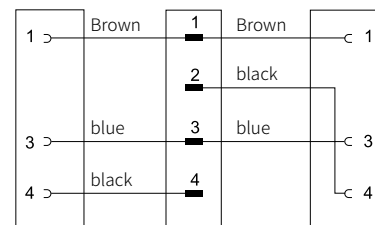

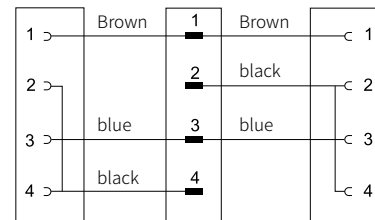

⑦
3-core circuit diagram











⑧
4-core circuit diagram











IO CABLE

	M8 Quick connect	M8 Quick connect	M8 Docking connection	M8 male	M8 female	M8 male 90°	M8 female 90°
							
3-pole Part No.	908331	908371	908002	908601	908621	908441	908521
4-pole Part No.	/	/	/	908611	908631	908461	908541
Cable outlet diameter	0.14...0.34 mm ²	0.14...0.34 mm ²	0.14...0.34 mm ²	0.14...0.5 mm ²	0.14...0.5 mm ²	0.14...0.5 mm ²	0.14...0.5 mm ²

		M8 male		M8 female		M8 male 90°		M8 female 90°	
									
Pole		3-pole	4-pole	3-pole	4-pole	3-pole	4-pole	3-pole	4-pole
black	Fixed	908001-610-XXXX	908011-611-XXXX	908041-610-XXXX	908061-611-XXXX	908021-610-XXXX	908031-611-XXXX	908081-610-XXXX	908101-611-XXXX
black	Flex	908001-630-XXXX	908011-631-XXXX	908041-630-XXXX	908061-631-XXXX	908021-630-XXXX	908031-631-XXXX	908081-630-XXXX	908101-631-XXXX
orange	Anti-weld slag	908001-050-XXXX	908011-051-XXXX	908041-050-XXXX	908061-051-XXXX	908021-050-XXXX	908031-051-XXXX	908081-050-XXXX	908101-051-XXXX



		M8 male to female		M8 male to female 90°		M8 male to M12 female		M8 male to M12 female 90°	
									
Pole		3-pole	4-pole	3-pole	4-pole	3-pole	4-pole	3-pole	4-pole
black	Fixed	988001-610-XXXX	988011-611-XXXX	988021-610-XXXX	988031-611-XXXX	988241-610-XXXX	988251-611-XXXX	988261-610-XXXX	988271-611-XXXX
black	Flex	988001-630-XXXX	988011-631-XXXX	988021-630-XXXX	988031-631-XXXX	988241-630-XXXX	988251-631-XXXX	988261-630-XXXX	988271-631-XXXX
orange	Anti-weld slag	988001-050-XXXX	988011-051-XXXX	988021-050-XXXX	988031-051-XXXX	988241-050-XXXX	988251-051-XXXX	988261-050-XXXX	988271-051-XXXX



	M12 Quick connect	M12 Quick connect	M12 Docking connection	M12 male		M12 female		M12 Large wire diameter	
									
4-pole Part No.	912491	912611	912002	912701	912741	912901	912941	912951	912051
5-pole Part No.	/	/	/	912721	912761	912921	912961	912791	912971
Cable outlet diameter	0.14...0.34 mm ²	0.14...0.34 mm ²	0.14...0.34 mm ²	4...6 mm	6...8 mm	4...6 mm	6...8 mm	8...10 mm	8...10 mm



	M12 male 90°		M12 female 90°		M12 Plastic housing		M12 Plastic housing		M12 Plastic housing		M12 Plastic housing	
												
4-pole Part No.	912821	912861	912981	913021	912702	912746	912905	912943	912822	912862	912985	913002
5-pole Part No.	912841	912881	913001	913041	912722	912762	912922	912963	912842	912882	913002	913042
Cable outlet diameter	4...6 mm	6...8 mm	4...6 mm	6...8 mm	4...6 mm	6...8 mm	4...6 mm	6...8 mm	4...6 mm	6...8 mm	4...6 mm	6...8 mm



	M12 Plastic housing L-Code		M12 Plastic housing L-Code		M12 male Shielded		M12 female Shielded		M12 male Shielded 90°		M12 female Shielded 90°	
												
4-pole Part No.	/		/		913301		913381		913341		913361	
5-pole Part No.	912753		912953		913321		913401		913421		913441	
Cable outlet diameter	8...10 mm		8...10 mm		4...6 mm		6...8 mm		6...8mm		6...8 mm	



IO CABLE

		M12 male			M12 female		
							
Pole		3-pole	4-pole	5-pole	3-pole	4-pole	5-pole
black	Fixed	912001-613-XXXX	912021-614-XXXX	912041-615-XXXX	912181-613-XXXX	912221-614-XXXX	912241-615-XXXX
black	Flex	912001-633-XXXX	912021-634-XXXX	912041-635-XXXX	912181-633-XXXX	912221-634-XXXX	912241-635-XXXX
orange	Anti-weld slag	/	912021-054-XXXX	/	/	912221-054-XXXX	/

		M12 male 90°			M12 female 90°		
							
Pole		3-pole	4-pole	5-pole	3-pole	4-pole	5-pole
black	Fixed	912081-613-XXXX	912101-614-XXXX	912121-615-XXXX	912321-613-XXXX	912341-614-XXXX	912361-615-XXXX
black	Flex	912081-633-XXXX	912101-634-XXXX	912121-635-XXXX	912321-633-XXXX	912341-634-XXXX	912361-635-XXXX
orange	Anti-weld slag	/	912101-054-XXXX	/	/	912341-054-XXXX	/

		M12 male to female			M12 male to female 90°		
							
Pole		3-pole	4-pole	5-pole	3-pole	4-pole	5-pole
black	Fixed	940001-613-XXXX	940021-614-XXXX	940041-615-XXXX	940172-613-XXXX	940202-614-XXXX	940222-615-XXXX
black	Flex	940001-633-XXXX	940021-634-XXXX	940041-635-XXXX	940172-633-XXXX	940202-634-XXXX	940222-635-XXXX
orange	Anti-weld slag	/	940021-054-XXXX	/	/	940202-054-XXXX	/

		M12 male to female 90°			M12 male to female		
							
Pole		3-pole	4-pole	5-pole	3-pole	4-pole	5-pole
black	Fixed	940101-613-XXXX	940121-614-XXXX	940141-615-XXXX	940171-613-XXXX	940201-614-XXXX	940221-615-XXXX
black	Flex	940101-633-XXXX	940121-634-XXXX	940141-635-XXXX	940171-633-XXXX	940201-634-XXXX	940221-635-XXXX
orange	Anti-weld slag	/	940121-054-XXXX	/	/	940201-054-XXXX	/

		M12 male to M8 female		M12 male to M8 female 90°	
					
Pole		3-pole	4-pole	3-pole	4-pole
black	Fixed	940561-610-XXXX	940581-611-XXXX	940601-610-XXXX	940621-611-XXXX
black	Flex	940561-630-XXXX	940581-631-XXXX	940601-630-XXXX	940621-631-XXXX
orange	Anti-weld slag	940561-050-XXXX	940581-051-XXXX	940601-050-XXXX	940621-051-XXXX

Circuit diagram

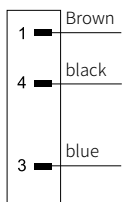

3-core single ended

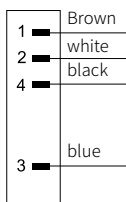

4-core single ended

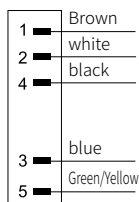

5-core single ended

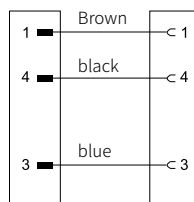

3-core dual ended

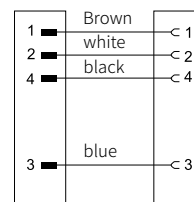

4-core dual ended

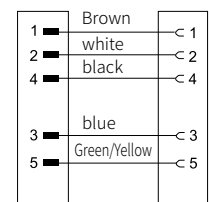





5-core dual ended



IO CABLE



	Slip-on cable sleeves	Snap-on cable sleeves	Label plates	Plastic M8 female cap	M12 Male cap	M12 Female cap	7/8" Male cap (Metal)	7/8" Female cap (Metal)
								
Part No.	990000	990001	990002	996060	981010	996050	955491	955691

	M8 connector tool	Tool for M12 connector with cable	Tool for M12 field-wireable connector	SHD 8 4 connector holder	SHD 12 4 connector holder
					
Part No.	600004001	600004002	600004003	63014102	63014104

	SHD 4 4D OD 4mm	SHD 6 4D OD 6mm	SHD 8 4D OD 8mm	SHD10 4D OD 10mm	SHD12 4D OD 12mm	SHD15 4D OD 15mm	SHD18 4D OD 18mm
							
Part No.	63014100	63014101	63014103	63014106	63014105	63014107	63014108

	45 ° outgoing line with programming port	45°	45 ° outgoing line with programming port	45°
				
Suppression Part No.	Profibus D-SUB-D9 955761	Profibus D-SUB-D9 955762	Profibus D-SUB-D9 955751	Profibus D-SUB-D9 955752

	M12 male, Panel mount, shielded			M12 female, Panel mount, Shielded		
						
Suppression	Devicenet A-Code 5 pin	Profibus B-Code 5 pin	Ethernet/Profinet D-Code 4 pin	Devicenet A-Code 5 pin	Profibus B-Code 5 pin	Ethernet/Profinet D-Code 4 pin
Part No.	913521-803-xxxx	913522-840-xxxx	913503-790-xxxx	913561-803-xxxx	913562-840-xxxx	914501-790-xxxx
Part No.	913524-803-xxxx	914121-840-xxxx	913506-790-xxxx	913564-803-xxxx	914164-840-xxxx	913546-790-xxxx

	M12 male			M12 Terminal			7/8" Terminal
							
Suppression	Devicenet A-Code 5 pin	Profibus B-Code 5 pin	Ethernet Profine D-Code 4 pin	CC-Link A-Code 4 pin	Devicenet A-Code 5 pin	Profibus B-Code 5 pin	Devicenet 5-pin
Part No.	942111	944111	949111	947001	913461	914041	978301

Logic distributors



Typically, the signals from many sensors are connected and each sensor is transmitted to a PLC via wires for processing. However, in many cases, the sensor signals only need to be input and /or logic processing in the process of transmission, and finally send a set of signals to the PLC, in this case, the active logic operation hub can reduce the field wiring and PLC operation load, with a variety of logic relationship options, IP67 protection level. The active logic hub can be fitted with up to 8 channels of 16 sensors or 4 channels of 16 sensors.



More information please visit
www.svlec.com

LOGIC DISTRIBUTORS

Drawing

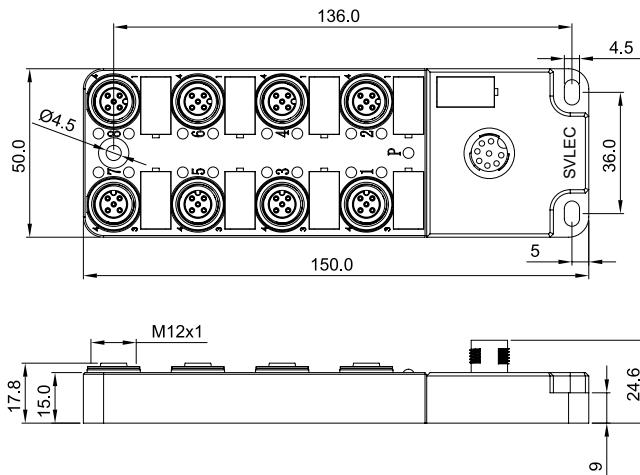

Output and Power

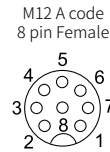
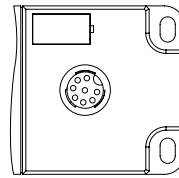

Contct	Define
1	24V
2	
3	0V
4	
5	OUT 1Y
6	OUT 2Y
7	OUT 3Y
8	OUT 4Y

I/O signal

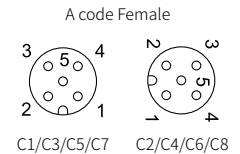
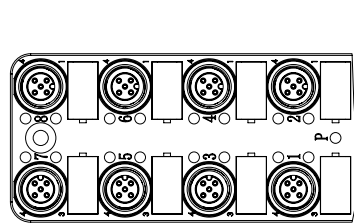

Contct	Define
1	24V
2	INPUT
3	GND
4	INPUT
5	FE

Circuit diagram

Logic AND

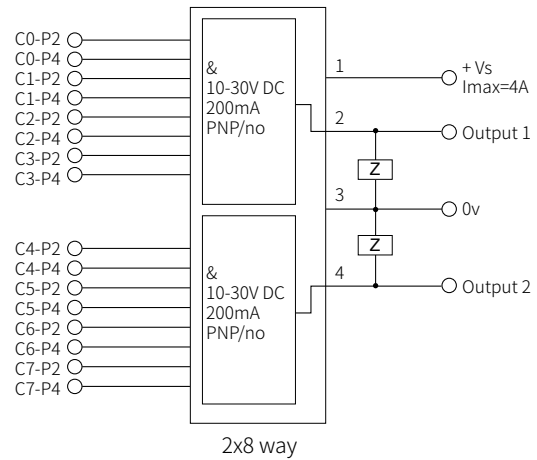
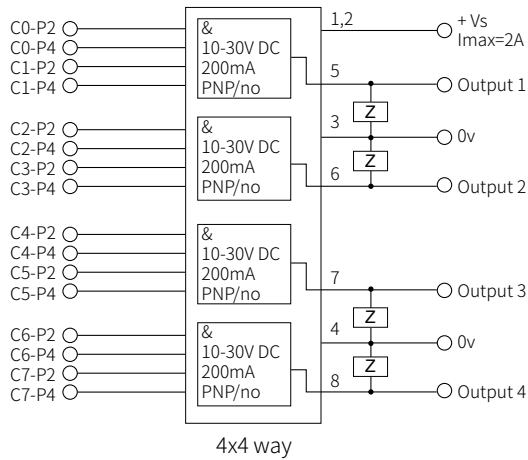

logic OR

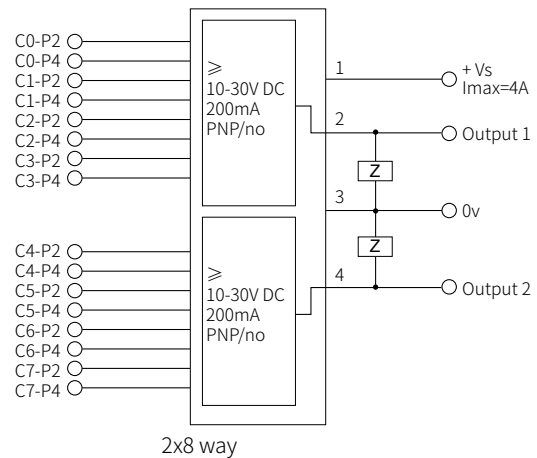
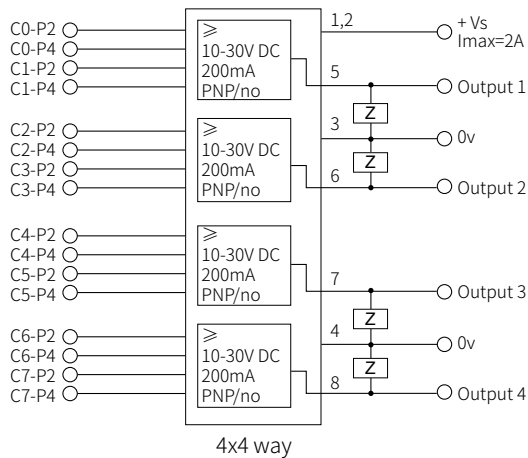

LOGIC DISTRIBUTORS

AND / OR logic operation on location minimized amount of cabling

- 4x4、2x8、Logic and、Logic or、Programmable custom optional
- Flat robust design
- 5/8-pin M12-connector for the connection line to the control unit
- LED status displays
- System of protection IP67
- Simple vibration-proof connection of sensor leads



Ordering information	4×4 way logic and	2×8way logic and	4×4 way Logic or	2×8 way Logic or	16 way programmable
Type	AG1204	AG1208	OG1204	OG1208	XG1216
Part No.	508100	508101	508200	508201	508300
Technical data					
UB	18...30 V DC				
Power indicator	Green LED				
Signal indicator	Green LED				
Input connect	M12, A code, Female				
Logic output	M12, A code, Male				
I/O Port number	16				
Input	4x4 (PNP)	2x8 (PNP)	4x4 (PNP)	2x8 (PNP)	Max. 16 (PNP)
Output	4 (PNP)	2 (PNP)	4 (PNP)	2 (PNP)	Max. 4 (PNP)
Programmable	No				Yes
Max loading current, Sensor/channel	200mA				
Max loading current, Actuator/channel	500mA				
Port status indicator	Yes				
Total current	2A	4A	2A	4A	2A
Protection degree IEC 60529	IP 67 (Correctly connected)				
Operate temperature Ta	-25...+60 ° C				
Storage temperature	-30...+70 ° C				
Fasten	3 *mount holes				
Size (L× W × H)	150×50×18 mm				
Housing material	PA				